

Instruction for Use

021341/08/07

Laser Precipitation Monitor

5.4110.xx.x00

V2.4x STD

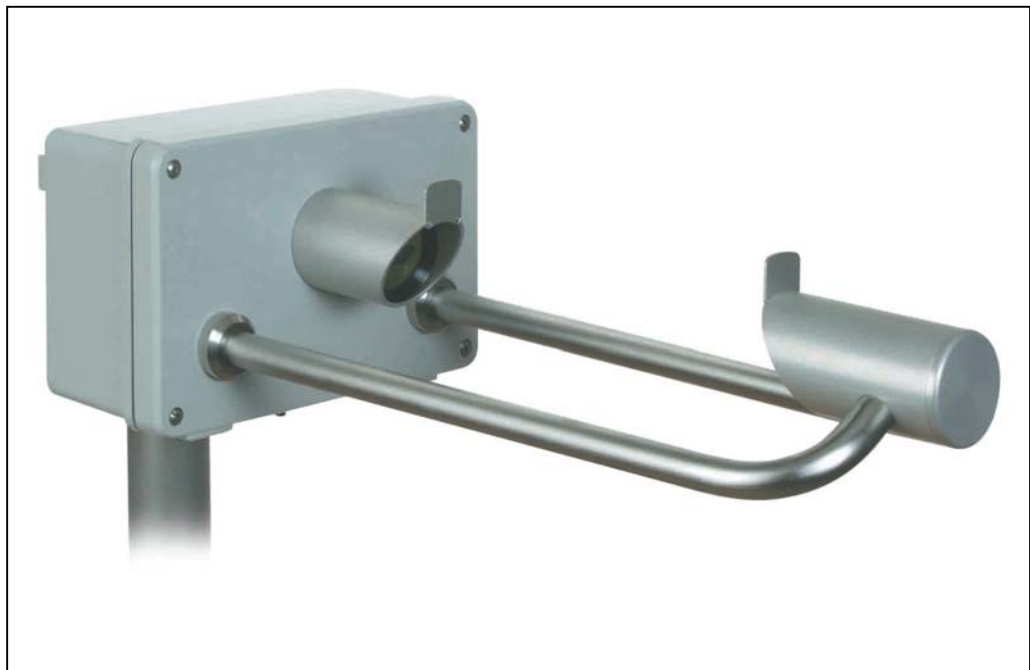

Contents

1	Models	4
2	General	4
3	Mode of Operation of the Laser Precipitation Monitor	5
4	Construction of the Measuring Instrument	7
4.1	Heating	11
4.1.1	Variant Extended Heating (5.4110.x1.xxx)	11
5	Installation.....	12
5.1	Suggestions for Mounting Place.....	12
5.2	Mast.....	13
5.3	Installation of Sensor.....	14
5.3.1	Mounting Angle	15
5.3.2	Mounting of the Housing Cover	16
5.3.3	Electrical Installation	16
5.3.4	Closing the Instrument Cover	19
5.3.5	Optocoupler output	19
6	Maintenance	20
6.1	Cleaning	20
6.2	Calibration	20
6.3	Checking the sensor.....	20
6.3.1	Checking the LED's	21
6.3.2	Checking by means of a terminal program	22
7	Serial communication.....	23
7.1	General telegram format	24
7.2	List of Commands	25
7.2.1	Communication commands	26
7.2.2	Reset / Version commands.....	27
7.2.3	Data telegrams commands.....	28
7.2.4	Time / Date commands.....	29
7.2.5	Diagnostics commands.....	30
7.2.6	Calibration commands	34
7.2.7	Quantity measurement commands	35
7.2.8	Digital output commands	36
7.3	Data Telegrams.....	39
7.3.1	Telegram 4/5: Synop, Metar, Disdrometer, optional measuring channel.....	39
7.3.2	Telegram 6/7: Synop, Metar, optional measuring channel	48
7.3.3	Telegram 8/9: Synop, Metar, optional measuring channel truncated	50
7.3.4	Telegram 10: Synop, Metar, optional measurement channels, averaging.....	52
7.3.5	Telegram 3: Particle-Event	54
8	Technical Data.....	55

9	Wiring Diagram	59
10	Declaration of Conformity	62

Figure

Figure 1:	Measurement of the precipitation particle	5
Figure 2:	Explanation of the measuring principle	5
Figure 3:	Schematic Block Diagram	7
Figure 4:	Side view	8
Figure 5:	Top view	8
Figure 6:	View of the electronics Rev.B	9
Figure 7:	View of the electronics Rev.A	10
Figure 8:	Example for an appropriate mast foundation	13
Figure 9:	Strap housing	15
Figure 10:	Strap, Mast, Mounting angle	15
Figure 11:	Screen cable connection to the cable gland	17
Figure 12:	Connection of power supply (here 115 or 230VAC) with ferrite tube and binder	18
Figure 13:	Examples for the connection to the opto-couplers	19

Table

Table 1:	Example for the speed of liquid particles.....	6
Table 2:	List of baud rates with telegram BR	26
Table 3:	Parameter 17 (command D1 and D2)	37
Table 4:	Parameter 19 (command D1 and D2)	38
Table 5:	Disdrometer class binning of diameter and speed	45
Table 6:	Code table SYNOP / METAR	46
Table 7:	Intensity steps SYNOP	47
Table 8:	Intensity steps METAR	47

1 Models

Order-No.	Operating Voltage	Option Meas. Channel	Option Extended Heating	
5.4110.00.000	24V~/= AC/DC	no	no	
5.4110.10.000		yes		
5.4110.00.100	115V~ AC	no		
5.4110.10.100		yes		
5.4110.00.200	230V~ AC	no		
5.4110.10.200		yes		
5.4110.00.300	12...24V= DC	no		
5.4110.10.300		yes		
5.4110.01.000	24V + 26V~/= AC/DC	no		yes
5.4110.11.000		yes		
5.4110.01.100	115V~ AC	no		
5.4110.11.100		yes		
5.4110.01.200	230V~ AC	no		
5.4110.11.200		yes		
Electrical outputs for all versions: RS485/422 and two optocouplers.				

2 General

The Laser Precipitation Monitor serves as measuring value transmitter, and is well-suited for the measurement and detection of different types of precipitation such as drizzle, rain, hail, snow, and mixed precipitation.

The acquisition comprises the types of precipitation, intensity, and the spectrum. All measuring values are available for the user via an RS 485/422 interface. In addition, the instrument is equipped with two digital outputs (optocouplers), which indicates, for example, amount and state of precipitation. The optical components are equipped with an integrated heating.

Instruments with „optional measuring channels” are able to connect temperature, rel. humidity, wind speed, and wind direction sensors in addition. These values are available, as well, via the RS 485/422 interface.

On sites with rough climate the version “extended heating” is available.

3 Mode of Operation of the Laser Precipitation Monitor

A laser-optical beaming source (laser diode and optics) produces a parallel light-beam (infrared, 785 nm, not visible). A photo diode with a lens is situated on the receiver side in order to measure the optical intensity by transforming it into an electrical signal.

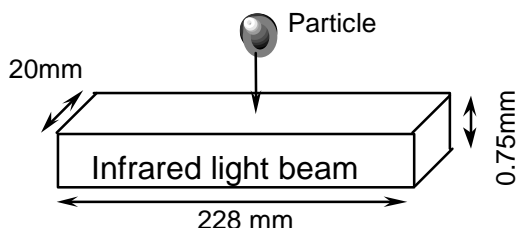

Figure 1: Measurement of the precipitation particle

When a precipitation particle falls through the light beam (measuring area $45,6\text{cm}^2(7\text{inch}^2)$) (Figure 1 and Figure 2) the receiving signal is reduced. The diameter of the particle is calculated from the amplitude of the reduction. Moreover, the fall speed of the particle is determined from the duration of the reduced signal.



Figure 2: Explanation of the measuring principle

The measured values are processed by a signal processor (DSP), and checked for plausibility (e.g. edge hits). Calculation comprises the intensity, quantity, and type of precipitation (drizzle, rain, snow, soft hail, hail as well as mixed precipitation), and the particle spectrum (distribution of the particles over the class binning)

The type of precipitation is determined from the statistic proportion of all particles referring to diameter, and velocity. These proportions have been tested scientifically (e.g. Gunn, R., and Kinzer, G.D., 1949, "The terminal velocity of fall for water droplets in stagnant air," *J. of Meteorology*, Vol . 6, pp. 243–248). In addition, temperature is included in order to improve the identification: Precipitations with a temperature of above $9\text{ }^{\circ}\text{C}$ are automatically accepted as liquid (exception: soft hail, and hail), and with a temperature of below $-4\text{ }^{\circ}\text{C}$ as solid. In the temperature range between, all forms of precipitation might occur.

Diameter [mm]	Fall speed [m/s]
0.2 (drizzle)	0.73
0.3 (drizzle)	1.2
0.8 (rain)	3.3
0.9 (rain)	3.7
1.8 (rain)	6.1
2.2 (rain)	6.9
3.2 (rain)	8.3
5.8 (rain)	9.2

Table 1: Example for the speed of liquid particles

The calculated data are memorized over one minute, and then transmitted via the serial interface.

The instrument is almost maintenance-free. Only the panes of the sensor heads should be cleaned, if necessary. An application all the year round is guaranteed by the integrated pane-heating. For application in areas of extreme weather conditions (for example high mountains) we recommend a model with “extended heating”. The effect of external light is minimized by a modulated light source of 173kHz (so-called „Lock-In“ technology). The effect of aging and temperature on the components as well as the soiling of the glass panes is compensated by controlling the receiving capacity. A watch-dog device controls the signal processor (DSP). The sensor controls its function by measuring and checking the receiving signals for soiling, as well as checking the laser driver for current and temperature. By using a flash-memory the internal software can be updated any time via the serial interface.

The following outputs are available: an electrically isolated serial interface (RS485) as well as two digital outputs (optocoupler). Thanks to the configurable digital outputs this sensor can be used as an alternative for precipitation monitors (e.g. IRSS88 or Thies 5.4103.10.000), and for precipitation sensors (e.g. tipping bucket).

The function of the digital outputs is programmable. For example: output 1

0,1mm or 0,01 resp. 0,005 mm precipitation per pulse corresponding to the cumulatively measured precipitation quantity. Output 2, for example, as precipitation event monitor, or as additional event output „solid precipitation“ (snow, snow-grains, soft hail, hail) in conjunction with output 1.

In addition, the following sensors can be connected optionally („Option Measuring Channels“):

- temperature (Pt100, not available with option “Extended Heating”)
- relative humidity (0-1V / 0-100% rel. humidity)
- wind speed (frequency 0- 630 Hz for example 4.3519.00.000)
- wind direction (serially synchronous for example 4.3129.00.000)

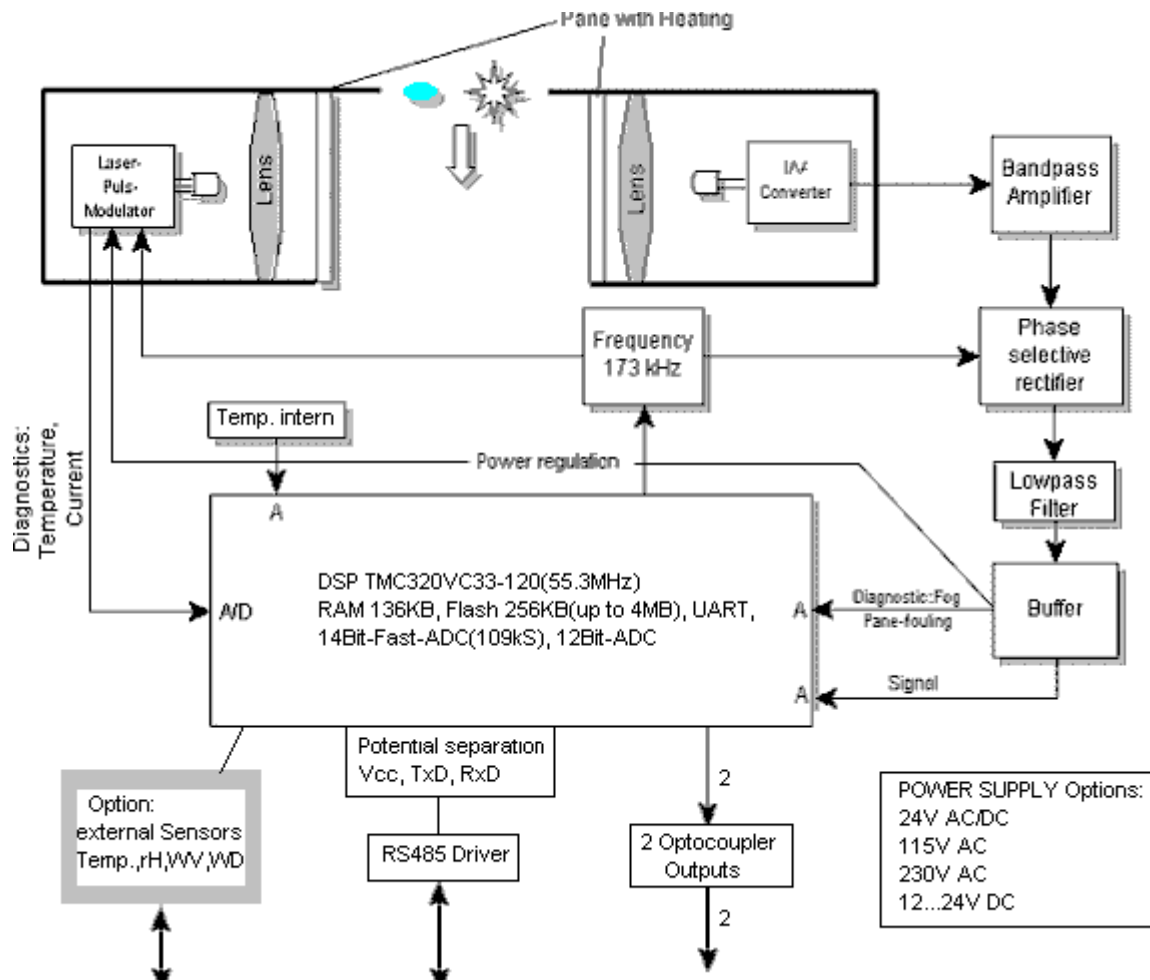

Figure 3: Schematic Block Diagram

In explanation of the construction, and the basic function the block diagram (Figure 3) shows schematically the most important functional connections (variant “Extended Heating” not shown).

4 Construction of the Measuring Instrument

The Laser Precipitation Monitor consists of the following: a varnished aluminium housing, protection IP 65, a laser head (anodised aluminium), fixed at the housing cover, a receiver head (anodised aluminium) fastened by means of carrier arms (see also Figure 4 and Figure 5)

The aluminium housing contains the electronics with all necessary interfaces. Furthermore, the electronics is equipped with light diodes (LED’s), which facilitate an easy and efficient check resp. diagnosis of the sensor even without serial data connection (Figure 6 or Figure 7). In the chapter “Maintenance” (see Ch. 6) you find a functional description of the LED’s.

The replaceable laser head consists of a laser driver circuit board (incl. laser diode), a rectangular window for the beam forming, a lens and a heated glass pane. The electrical connection to the electronics is carried out by a 10-pole ribbon flat cable leading to the “Connector Laser”.

The receiver head consists of a receiving circuit board with photo diode and electronics, a lens and a heated glass pane. The electrical connection is done by a 6-pole ribbon flat cable leading to the “Connector Receiver”.



Attention: Do not look into the invisible laser beam! In case the laser caution labels on the housing are not legible any more the sensor must not be operated!

Even with a longer exposure time the intensity of the invisible laser beam is considered as safe for the human eye (without using optical instruments). A skin-contact with the invisible radiation is, in general, harmless.

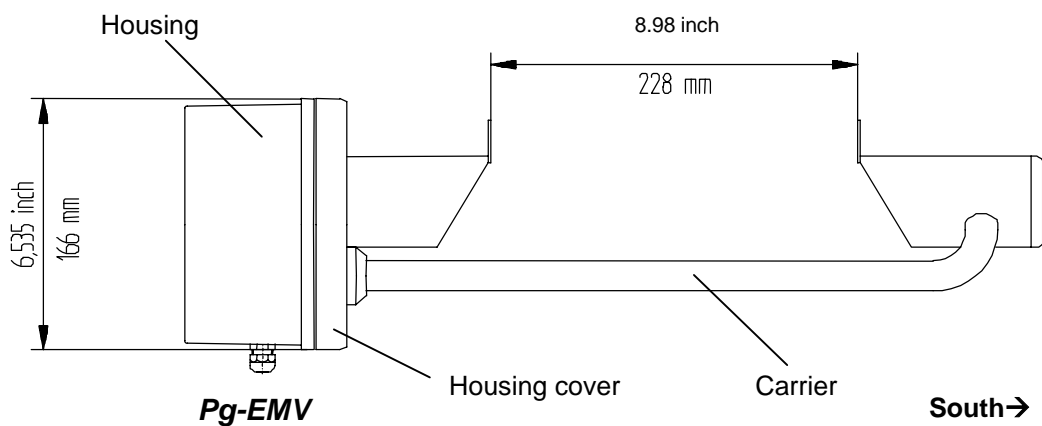

Figure 4: Side view

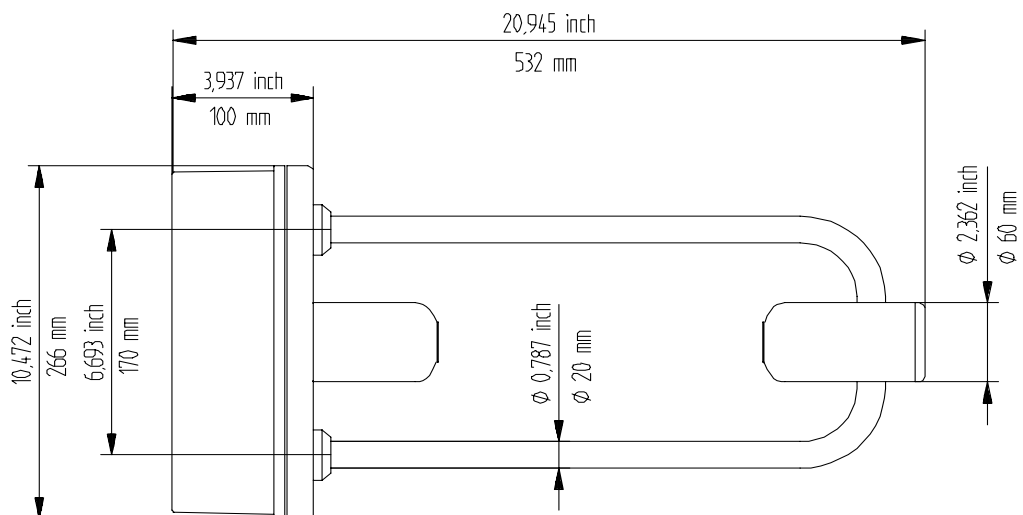

Figure 5: Top view

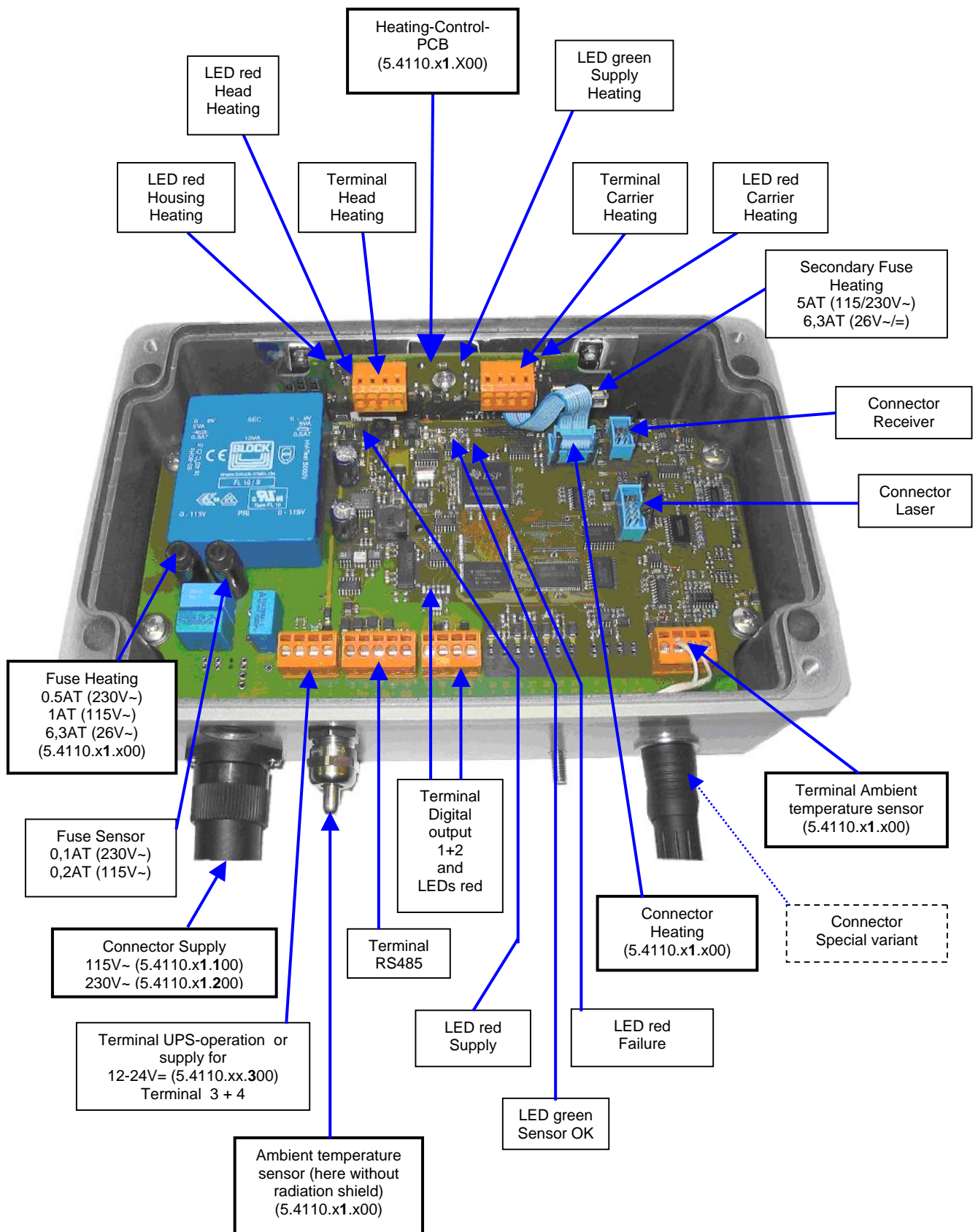
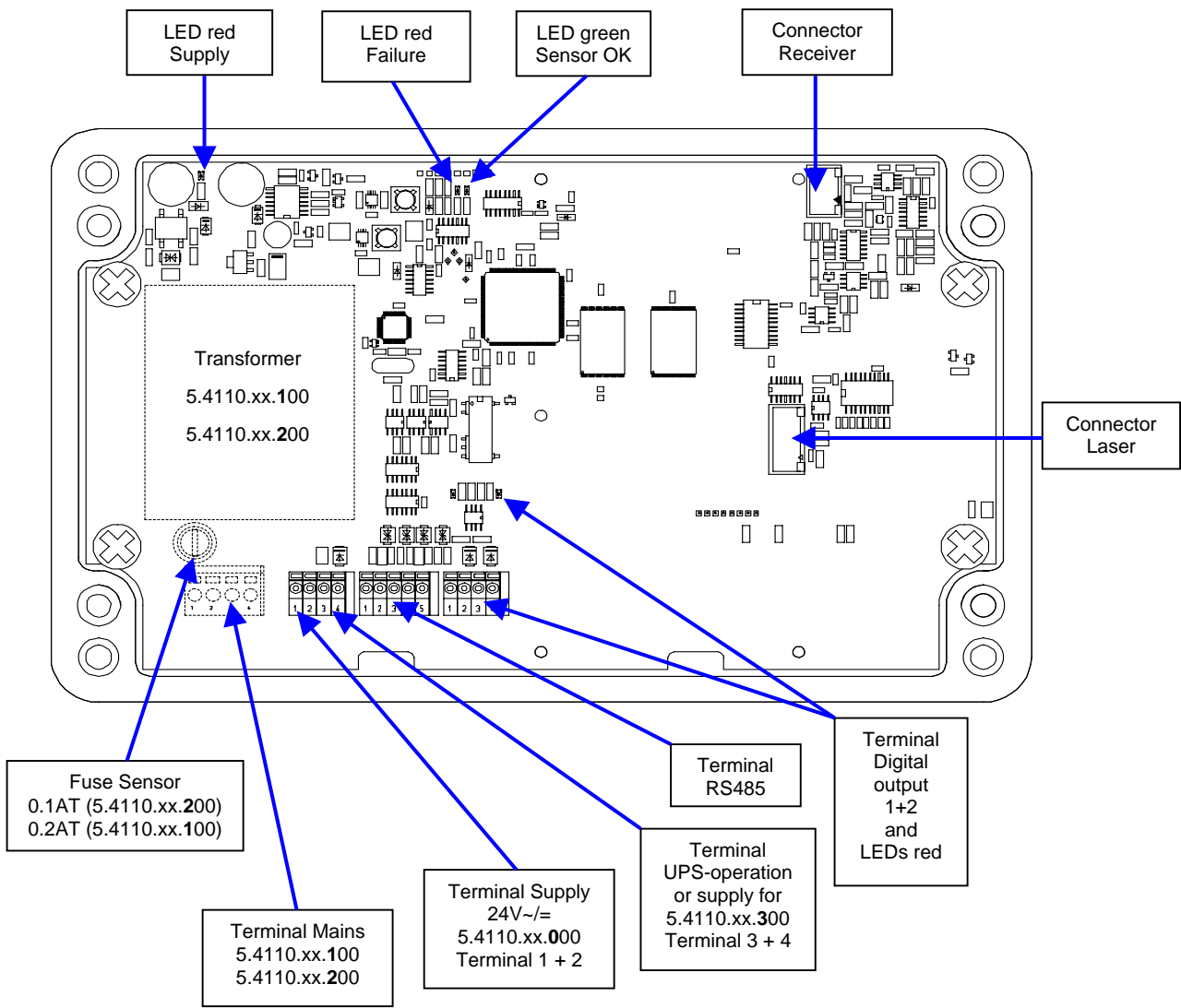

Figure 6: View of the electronics Rev.B

(here: PCB Rev.B (terminals 1 to 38 orange) 5.4110.01.200, version “Extended Heating”)

Note: Differences to variant 5.4110.00.200 (Rev.B) are accentuated with heavy print frames.



**Figure 7: View of the electronics Rev.A
(PCB Rev.A: terminals 1 to 38 green)**

4.1 Heating

All sensor variants have heated glass panes on both heads to prevent interferences through freeze up, steaming up or similar. The heating power is controlled in subject to the ambient conditions.

The heating current are measured for self diagnostic and could be read through the diagnostics command ("DD", only available with PCB Rev.B, see Figure 6).

4.1.1 Variant Extended Heating (5.4110.x1.xxx)

In addition to the two glass pane heatings this variant has 3 heating circuits to prevent against malfunction due to icing and packing of snow :

1. Housing (top side)
2. Heads (under the stainless steel components)
3. Carriers (straight section of the carriers at the receiver head)

This three heating circuits are controlled separately against the ambient temperature (ambient temperature sensor, see also Figure 6). The heating power varies from 10% to 100%. The heatings are switched on from a measured temperature under 3°C.

Whether the respective heating circuit is switched on, can be checked by observing the corresponding red LED on the Heating-Control-PCB (Figure 6).

The heating currents and the supply voltage of the heating are measured for self diagnostic and could be read through the diagnostics command ("DD").

With the commands „HK“, „HB“ and „HG“ (see Ch. 7.2.5) you can individually switch on a heating circuit for one minute for testing.

5 Installation



Attention: *The instrument must be mounted and wired only by a qualified expert, who knows and observes the generalities of technics, and applicable regulations and norms.*

5.1 Suggestions for Mounting Place

Please note the following when selecting the location:

The sub-surface under the Laser Precipitation Monitor shall not consist of dark stone, asphalt or the like, as otherwise, in case of strong sunshine radiation, the ascending air will form so-called streaks. As sub-surface we recommend a lawn.

Depending on the wind speed and wind direction the precipitation particles are swirled by the Laser Precipitation Monitor so that the fall speed is changed. This might cause a deterioration of the sensor quality. Therefore, you should avoid an installation in the open country (particularly mountain tops) or directly in the lee of an obstacle. Well-suited are flat locations with wind breaks (e.g. hedges).

According to the WMO-directive for precipitation measuring instruments the distance between the installed sensors and the next obstacle should be at least four times the height of this obstacle. If this is not practicable, at least keep an azimuth angle of $< 45^\circ$ with regard to the surrounding plants, buildings etc. Logically consistent would be also to mount the sensor on a mast top. We recommend a measuring height of at least 1m or rather 1.5 to 2m in snowy sites. Other devices should be mount with a distance of at least 1m on the same mast. The side distance to other objects should be greater than 2m.

We recommend to operate the Laser Precipitation Monitor in an enclosed area for human safety, although the intensity of the invisible laser beam is considered as safe for the human eye (without using optical instruments, Laser Class 1M according to EN 60825-1:1994 A2:2001). Pay attention to stand to local regulations regarding laser safety.

It is not advisable to install the Laser Precipitation Monitor directly on a street, because it is, for example, possible that water particles, whirled up by the vehicles, might lead to erroneous measurements. In this case, we recommend to install the instrument with a respective distance and height. At streets the alignment of the sensor should be not to the south, but at right angles with the street (receiver head farthest away to the lane).

5.2 Mast

The delivered mast holder of the Laser Precipitation Monitor is designed for a mast diameter of 48... 102 mm (1.9... 4 inch). The mast should be electro-conductive, and be connected to the ground potential (foundation/grounding bound). Otherwise, the sensor is to be connected to the ground potential by a cable with minimum 6mm² diameter. Due to its sensitivity the sensor is susceptible to vibrations. Therefore, the mast diameter should be preferably large, and the mast should be fixed on a concrete foundation by means of firmly welded-on struts (Figure 8). From a mast height of approx. 2 m up the mast should be additionally fixed by three stay-wires.

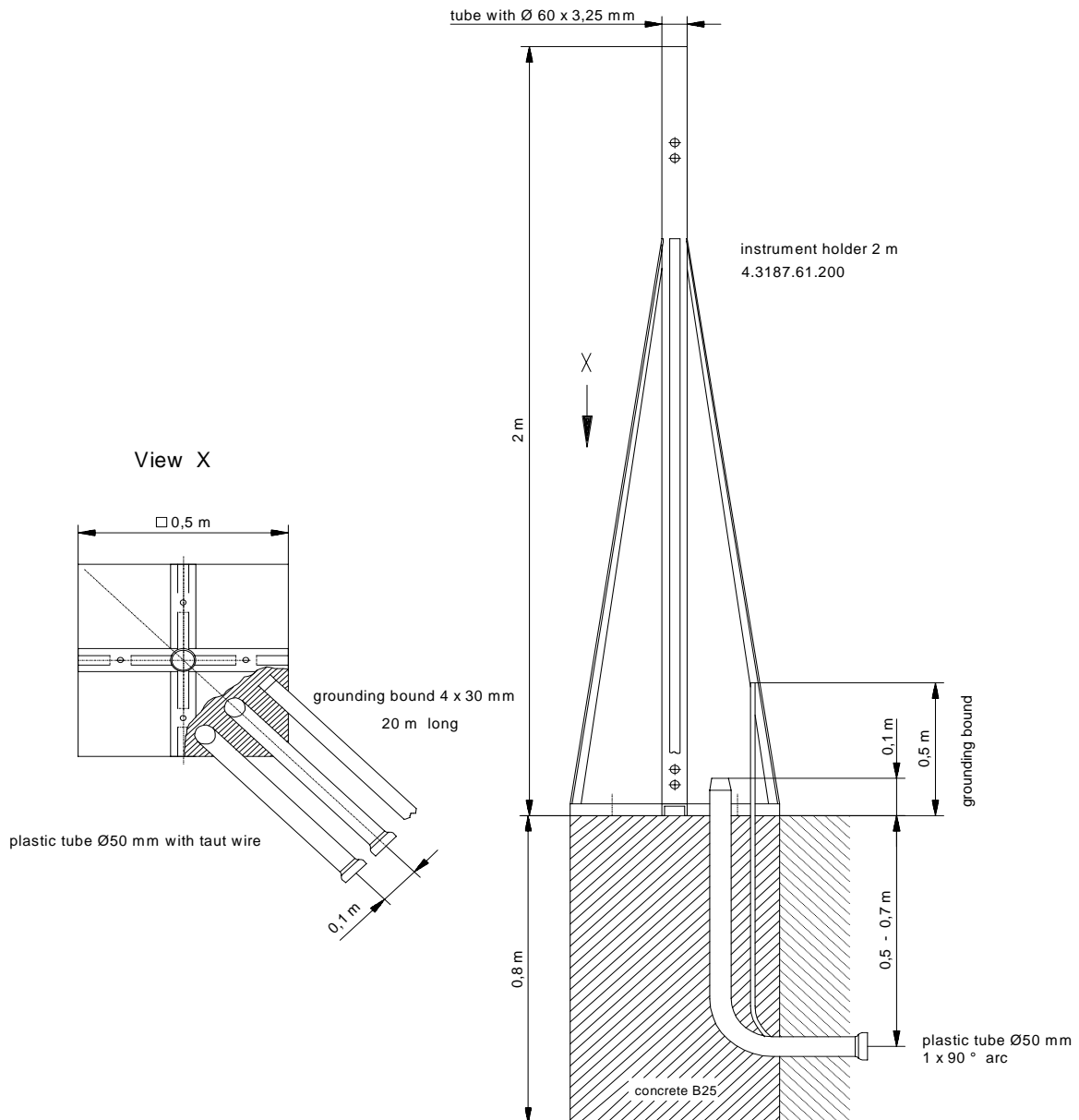

Figure 8: Example for an appropriate mast foundation

(Remark: Connect grounding bound to the holder)

5.3 Installation of Sensor



Attention: *Do not look into the invisible laser beam!*

In case the laser caution labels on the housing are not legible any more the sensor must not be operated!

Even with a longer exposure time the intensity of the invisible laser beam is considered as safe for the human eye (without using optical instruments).

A skin-contact with the invisible radiation is, in general, harmless.



Attention: *Head and carrier heatings could be hazardous hot!
Burn Hazard! (applies only for 5.4110.x1.xxx)*

Tools:

- Allen wrench (Inbus) SW4
- Combination wrench or ring spanner wrench SW10
- Combination wrench SW16 und SW20
- Tools to work in cables (for example: skinning tool, gripper for cable end sleeve)
- Screw driver for slotted screws, blade width 2 and 6 mm
- Tools for the shortening of straps

5.3.1 Mounting Angle

First, the mounting angle (with or without housing) should be fastened to the mast. Because of the shading effect of the mast the angle is to be mounted at the highest possible place. Align the angle to the south acc. to Figure 10 ($\pm 10^\circ$, Northern hemisphere), and fasten it at the top of the mast. It is advisable to have a second person holding the Laser Precipitation Monitor during the mounting. In case no second person is available, it is also possible to separate the mounting angle from the Laser Precipitation Monitor (2 nuts M6 below, 2 screws above [accessible after removing the housing cover]).

Does only apply to the models with supply 115 VAC/230 VAC:

In case an electro-conductive mast is used, the straps should be fastened directly, i.e. without insulator. If the mast is not electro-conductive, a potential equalisation should be established between ambience (for ex. fundament) and sensor by means of a cable ($>6\text{mm}^2$).

1. Cut 2 pieces of the necessary length off the strap (1 meter) acc. to the table below.
2. Insert the strap into the housing from the screw head side, and bend a projection of 20 mm over the ridge (Figure 9).
3. Put the free end of the prepared clamp around the mast and the mounting angle, and screw it on (Figure 10).
4. 2 Straps are provided for each mounting angle.

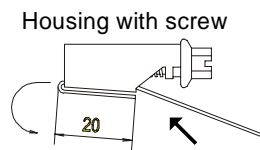

Figure 9: Strap housing

Mast Ø	Mast Ø	Length strap
48 mm	1.9 inch	250 mm (10 inch)
60 mm	2.4 inch	310 mm (12.2 inch)
80 mm	3.2 inch	370 mm (14.6 inch)
90 mm	3.5 inch	400 mm (15.8 inch)
102 mm	4 inch	440 mm (17.3 inch)

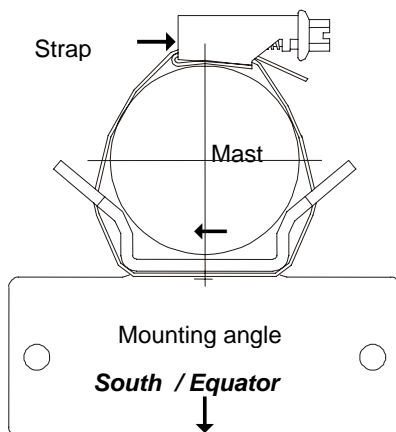

Figure 10: Strap, Mast, Mounting angle

5.3.2 Mounting of the Housing Cover

Remove, first, the 4 screws in the edges. Afterwards, turn down the cover carefully.

When the housing is open, please take care that no humidity (precipitation) can lay down on the electronics.

5.3.3 Electrical Installation



Attention: *The instrument must be mounted and wired only by a qualified expert, who knows and observes the generalities of technics, and applicable regulations and norms.*



ATTENTION: *Do not look into the invisible laser beam!
In case the laser caution labels on the housing are not legible any more the sensor must not be operated!*



Attention: *Head and carrier heatings could be hazardous hot!
Burn Hazard! (applies only for 5.4110.x1.xxx)*

After the housing cover (CH. 5.3.2) has been opened, electrical connection can be carried out according to wiring diagram (CH.9).

In order to carry out an EMC-compatible installation the cable screen/shielding (except the supply cable, which, in general, is not shielded) is to be connected to the contact spring of the screwed cable gland (Figure 11).

1. With the Standard Contacting (see Figure 11-1)

- Strip back the outer sheath and screen (shielding)
- Make a round cut in the outer sheath approx. 15 mm along but do not remove the sheath
- Guide the cable through the cable gland
- Pull off the outer sheath
- Pull back the cable until the connection is made between the cable screen and contact spring
- Turn shut... and it is ready for use!

2. With thin Wires without an Inner Sheath (see Figure 11-2)

- Strip back the outer sheath
- Pull back the screen braid approx. 15-20mm over the outer sheath
- Insert the cables into the cable gland until the contact is made between the cable screen and contact spring
- Turn shutand it is ready for use!

3. When Routing the Cable Screen to another Connection (see Figure 11-3)

- Expose the screen braid approx. 10 mm
- Guide the cable through the cable gland until the connection is made between the cable screen and contact spring
- Turn shut...and it is ready for use!

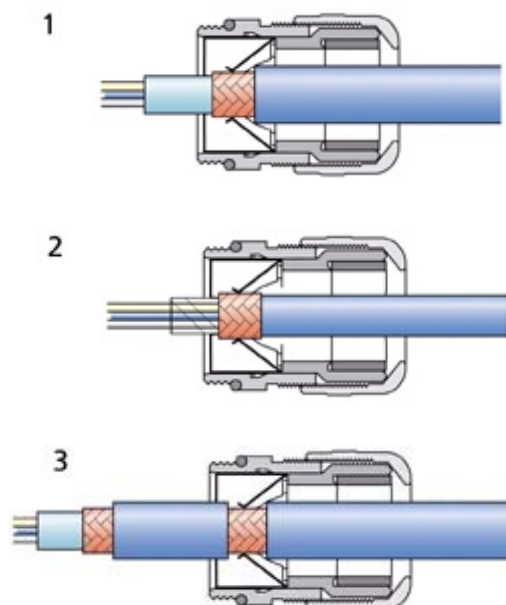

Figure 11: Screen cable connection to the cable gland

The cables are guided through the respective cable gland to the sensor connecting terminals (Figure 6 or Figure 7), see also wiring diagram (CH. 9). They are connected by means of the respective tension clamp technique.

For the orange-coloured connecting terminals put a commercially available screw-driver with a blade width of up to 2mm resp. 0,1 inch into the upper rectangular opening. Insert the respective cable into the lower round opening. After the screw driver has been removed the cable is fixed by spring tension.

With the green- and orange-coloured connecting terminals (only for PCB Rev.A) please press down the orange-coloured lever by means of a screw-driver (cable 0,1-1,5 mm² resp. 26-16 AWG).

After having been guided through the cable gland into the cover, the supply cable is to be shielded against EMC-disturbances by means of the available grey ferrite tube. For this, after connection of the cables, the ferrite tube is to be fastened directly at the cover panel by means of the binder (see Figure 12).

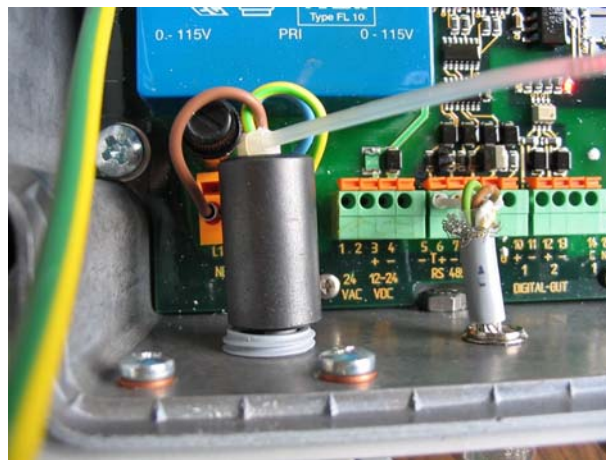

Figure 12: Connection of power supply (here 115 or 230VAC) with ferrite tube and binder

After all connections have been established the supply can be switched on:
With an operating supply the red Supply-LED (top left corner of PCB) must flash continuously (Figure 6 or Figure 7). The green Sensor-OK-LED flashes with 5hz when the signal processor operates properly (after approx. 5 seconds). In case the LED's show a different behaviour please refer to chapter 6.3.1 how to determine the possible error .

NOTE: All supply voltages must be potential-free (exception 115VAC and 230VAC). For example, with the 24VAC-supply there must be used a separate winding of the transformer only for this sensor. In addition, we recommend to provide for a separator in the installation (for example switch or fuse), and to mark this.

When the instrument operates properly the cover should be fastened (see the following chapter), and the instrument should possibly be configured by means of a commercially available terminal program (CH. 7)

5.3.4 Closing the Instrument Cover

Lift up the housing cover carefully, and take care that no cable is jammed between cover and housing. Moreover, the gasket must fit in the groove provided for. Tight the screws strongly and crosswise to ensure the proper sealing of the housing (torsional moment of at least 2,0Nm).

5.3.5 Optocoupler output

In Figure 13 you see 2 ways of connecting external instruments (“pull-up”-circuit to clamp 10/11 (output 1) and “pull-down” circuit to clamp 12/13 (output 2)). The load resistor R should preferably be low (for example $V_{cc}=5V$, $R = 5V/1mA = 5\text{ k}\Omega$). The connecting cables should be shielded, and the receiving input should be equipped with respective EMC-filters (not showed in Figure 13).

For the optical check of the outputs near the clamp resides two red LED’s, which light when the respective output is on.

With the command “D1” (respective “D2”, see CH. 7.2.8) you can configure the outputs.

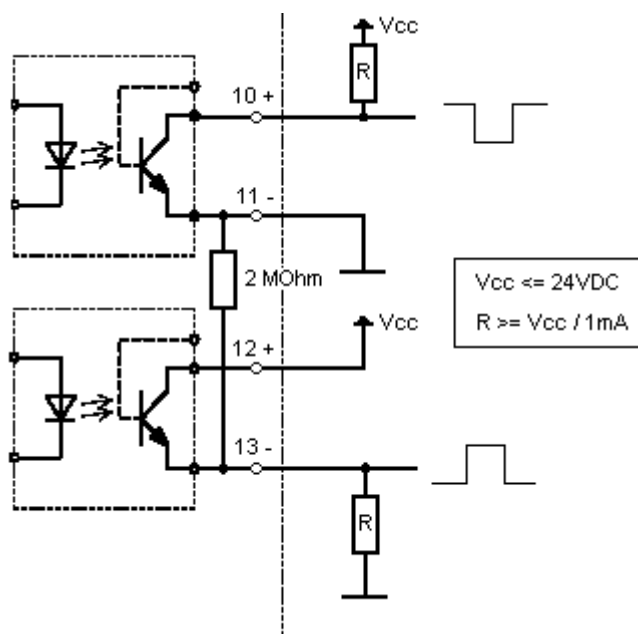

Figure 13: Examples for the connection to the opto-couplers

6 Maintenance



ATTENTION: *Do not look into the invisible laser beam!*



Attention: *Head and carrier heatings could be hazardous hot!
Burn Hazard! (applies only for 5.4110.x1.xxx)*

6.1 Cleaning

Approximately every 3 months the glass panes of the sensor should preventively be cleaned. Depending on the location this period might be different. Please use a commercially available cloth which is used, for example, for cleaning spectacles.

If the Laser Precipitation Monitor outputs the error message 1 “static signal out of allowed range” (see diagnostic command “DX”, CH. 7.2.5) or frequently the output “Precipitation (not identified)” appears, and the error remains still after the cleaning, the instrument has to be sent-in to the manufacturer for inspection.

Insect nests, spider webs, pollen flight sediments or the like shall be removed regularly. Depending on the environment and season the periods for control might be different.

6.2 Calibration

A calibration is necessary with the replacement of certain components. It is carried out in the factory.

6.3 Checking the sensor

The simulation of precipitation can be generated as follows:

Move an object (or a finger) at least 15 times per minute as quick as possible through the invisible laser beam between the sensor heads. Then, with the next minute-change, the sensor outputs the precipitation type “Precipitation (not identified)” as well as a respective precipitation quantity. This simulation can be started five minutes after the instrument has been switched on.

6.3.1 Checking the LED's

In case no terminal program with PC is available the checking of the Laser Precipitation Monitor is limited to the control of the following LEDs. You will see them after removing the cover (see Figure 6 or Figure 7):

- SUPPLY (red, on the left above) must shine when AC supply is switches on.
- SENSOR-OK (green, middle above) flashes with 5Hz if DSP operates properly
- FAILURE (red, middle above) flashes with 5Hz if an error and with 0.5Hz if an warning has been detected

In case the SUPPLY-LED does not flash the supply should be checked. The models with „115VAC“ and „230VAC“ operating voltage a safety fuse (“Fuse Sensor”, see Figure 6 or Figure 7) situated directly above the orange connecting terminal „L1“and “N” (left, below). All models have an additional electronic fuse for the supply. In case this fuse has activate the external supply must be switched off for approx. 30 seconds so that the fuse can cool down.

If the FAILURE LED flashes you should control the glass panes, and maybe clean them. After the supply has been switched on the FAILURE LED lights up for 5 seconds.

Additional for variant “Extended Heating” (5.4110.x1.x00):

- LED “SUPPLY HEATING” (green, Heating-Control-PCB) must be on when the supply is OK.
- LED's (red, Heating-Control-PCB) for checking the three heating circuits must be on, when the respective circuit is switched on (Command “HG”, “HK” and “HB”).

The primary fuse of the heating supply (“Fuse Heating”) is located beside the “Fuse Sensor” (see Figure 6). The secondary fuse is situated on Heating-Control-PCB.

6.3.2 Checking by means of a terminal program

First, the Laser Precipitation Monitor must be connected to the respective COM interface of the used PC by an interface converter (RS485/RS232).

Start a terminal program, and configure the interface according to the sensor interface (baud rate, parity, etc.). Now the Laser Precipitation Monitor is ready for request. See also chapter 7. The factory setting of the serial interface: 9600 Bd, 8, N, 1, full-duplex, ID:00

Check the control voltage (4010 ± 5) through the diagnostic command („<id>dd“). In case the value is outside the value range, and cleaning the glass panes shows no effect the Laser Precipitation Monitor is to be sent-in for inspection. Moreover, the internal temperature (without sun radiation max. $\pm 4^\circ$ difference compared with the ambient temperature, does not apply to model 5.4110.x1.x00 when heating is on [extended heating]) as well as the laser driver temperature (approx. 10° higher than the internal temperature) can be checked. Please note that for variant “Extended Heating” (9.4110.x1.x00) the difference between internal and ambient temperature is higher, when the heating is on.

Switch-on the telegram „Particle Event“ („<id>tm00003“). Drop a preferably spherical object with a diameter smaller than 8mm through the measuring area.

Example 1: with 4 mm steel ball (dropped from the middle of the laser head screen):

Reply from the sensor:

9476;588;497800898;4.04;00.90;3.71;00.89;+19

Diameter: 4.04 mm

Speed: 0.9 m/s

Example 2: with finger moving through the measuring area:

Reply from the sensor:

16370;2158;499106556;7.71;00.39;6.19;00.34;+19

Re-activate the starting conditions after test end, for example, the data format set before.

7 Serial communication

An RS485 interface (4-wire or 2-wire mode, changed by command "BD", see CH. 7.2.1) with several baudrates (command "BR") is available at the Laser Precipitation Monitor for the serial communication.

The communication can be carried out, for example, by means of a standard terminal program and a PC. With a Windows-based operating system delivery, for example, contains Hyper Terminal. If necessary, it must be installed later.

4-wire / full-duplex mode (factory setting) :

The receive lines in the sensor are terminated with a resistance of 560 Ω when a so-called Jumper is directly above the contacts "R-" and "R+" on the 2-pole connecting-pin-line.; see wiring diagram (CH.9).

2-wire / half-duplex mode :

The transceiver lines in the sensor are terminated with a resistance of 560 Ω when a so-called Jumper is directly above the contacts "T-" and "T+" on the 2-pole connecting-pin-line.; see wiring diagram (CH.9).

NOTE: *Half-duplex mode*

In the sensor there are no so-called bias-resistors (pull-up and pull-down) to get the voltage level (>0.2V) for the RS485-norm, when the network is idle.

This resistors must be provided by the remote station (e.g. PC).

7.1 General telegram format

A fixed telegram format is used for the serial communication (<CR> means Carriage Return (enter key)) :

- Data request:
„<id>BB<CR>“ <CR> means carriage return (enter key)
- Change of parameters:
„<id>BBppppp<CR>“ <CR> means carriage return (enter key)

The single letters have the following meaning:

id: Device address number (00...99, initial value 00)
BB: two-digit command code (case-insensitive)
ppppp: A new parameter is set by entering a 5-digit value. The parameter is right-aligned, and must be completed with zeros from the left.

Example for a Change of Parameters:

The baud rate is to be set to 4 (corresponds to 4800 baud 8, N, 1) with the device address "00".
The respective command is:

„00BR00004<CR>“

Example data request:

The set record for the baud rate is returned with the command

„00BR<CR>“

Reply:

„!00BR00004“

The reply from the sensor is marked by an exclamation mark at the beginning of the return.

NOTE:

The receiving buffer of sensor can be cleared by sending a carriage return <CR>. In case the sensor has invalid or unintentional characters in the receiving buffer, it is advisable to send a <CR> at the beginning of the command, e.g. "<CR>00BR<CR>"

Error messages from the sensor (ID: "00"):	
"00CI00002"	Unknown command
"00CI00004"	Parameter out of allowed range
"00CI00008"	Incorrect command mode (see command "KY", CH. 7.2.1)

7.2 List of Commands

<id>: Device address (00...99, initial value "00", see command "ID", CH. 7.2.1)

Command ?

<id>? Help
description: Output list of commands
Example reply:
KY: Set/Get command mode (0:user, 1:config)
BR: Set/Get Baudrate (5: 9600Bd 8N1)
BD: Set/Get Duplex (0:Full, 1:Half)
ID: Set/Get Device Address
RS: Reset Sensor (1)
SV: Get Software Version
SB: Get Bootloader Version
SN: Get Serial Number
TM: Set/Get Telegram (3: Particle Event 4:SYNOP,METAR,Disdrometer)
(5: 4 + aux. Measuring Channels)
(6: SYNOP,METAR 7: 6+aux. Meas. Chan.)
(8: SYNOP,METAR short 9: 8+aux. Meas. Chan.)
(10: 7 + Averaging (Time: TO parameter))
TR: Request Telegram (4...10)
TO: Time interval telegram 10 (1...10 min)
ZH: Set Hour (0..23)
ZM: Set Minute (0..59)
ZS: Set Second (0..59)
ZD: Set Day (1..31)
ZN: Set Month (1..12)
ZY: Set Year (0..99)
ZT: Get Sensor Date + Time
ZB: Get Operation hours [2H]
AZ: Set/Get Time calibration [1.44s/d] (0...123, >100 neg.)
DD: Get Diagnostic Data
DX: Get Self Diagnostic
FM: Get Error Count
RF: Reset Error Count (1)
AT: Set/Get Temp. internal calibration [degree C] (0...106, >100 neg.)
AV: Set/Get Amount Adjustment (80...120%)
AU: Get Measuring Area
FT: Test Flash (1)
RA: Reset Amount (1)
PT: Get Time Duration Amount
D1/D2: Set/Get Digital Output 1/2
DA: Auxiliary Measuring Channel (Option)
HK/HB/HG: switch on heating for 1 minute (0:Off 1:On) head(K), holder(B),
housing(G)

7.2.1 Communication commands

Command KY

<id>KY<para5> Setting the command mode (0: normal, 1: configuration)
Description: Two modes are available:

- Normal mode (no setting of parameter possible)
- Configuration mode (all commands allowed)

Value range: 0,1

Initial value: 0 (set to zero by power up, no storing)

Command BR

<id>BR<para5> description: Setting the baud rate.
The communication can be carried out with different baud rates and parities. The setting range is from 1200baud to 115.2Kbaud, 7 or 8 data bits, no(N), even(E), odd(O) parity, 1 or 2 stop bits. The following parameter are defined for BR:

Parameter description:

	1200	2400	4800	9600	19200	38400	57600	115.2K
8N1	2	3	4	5 *	6	7	8	9
7E1	10	11	12	13	14	15	16	17
8E1	18	19	20	21	22	23	24	25
8O1	26	27	28	29	30	31	32	33
7N1	34	35	36	37	38	39	40	41
7O1	42	43	44	45	46	47	48	49
8N2	50	51	52	53	54	55	56	57
7E2	58	59	60	61	62	63	64	65
8E2	66	67	68	69	70	71	72	73
8O2	74	75	76	77	78	79	80	81
7N2	82	83	84	85	86	87	88	89
7O2	90	91	92	93	94	95	96	97

Table 2: List of baud rates with telegram BR

* Setting by the factory

Value range: 2..97

Initial value: 00005

Command BD

<id>BD<para5> Setting duplex-mode (full- ["0"] / half-duplex ["1"]).
Description: Setting for the using of a so-called 4-wire- (full-duplex, common called RS422) or 2-wire-communication (half-duplex, RS485).
Value range: 0,1
Initial value: 0 (full-duplex)

Note:

- We recommend concerning the simplicity the use of full-duplex communication
- If you change the duplex-mode please bear in mind that mostly a change of wiring and setting of the interface (-converter) is necessary.
- The latency period is 20ms. This means that after sending of a command within 20ms the switching of the direction must happen. And after receiving a answer from the sensor at the earliest time of 20ms a command can be send.
- Half-duplex operation: An idle-state of at least 0,2 V is to be caused by respective resistances of the opposite site (normally available in the interface converter

Command ID

<id>ID<para5> Setting of the device address for the communication.
Description: After setting of the address in the future this new <id> must be used for each new command.
Value range: 0...99
Initial value: 0

7.2.2 Reset / Version commands

Command RS

<id>RS00001 Reset of the sensor.
Description: Re-start of the sensor. Note: command mode has to be set to configuration before (see "KY", CH. 7.2.1)
Value range: 1
Initial value: 0

Command SV

<id>SV Request of the software version.
Description: Output of the software version (example reply: „!00SV00203“ -> V2.03)
Value range: -
Initial value: -

Command SB

`<id>SB` Request of the bootloader version.
Description: Output of the bootloader version (example reply: „!00SB00110“ -> V1.10), if supported by the bootloader.
Value range: -
Initial value: -

Command SN

`<id>SB` Request of the serial number.
Description: Output of the serial number.
Note: If the serial number is 0 the system parameters are adjusted wrongly. In this case, please have the instrument checked by the manufacturer.
Value range: 1...9999
Initial value: set in the factory

7.2.3 Data telegrams commands

Command TM

`<id>TM<para5>` Telegram selection measuring data (automatically send without request, automatic mode).
Description: Setting the telegram, telegram 3 to 10 (see CH. 7.3).
Telegram 1 and 2 are for internal test purpose.
Telegram 0 means no automatic sending, and is recommended when using the polling command “TR”.
Value range: 0...10
Initial value: 4 (5.4110.0x.xxx) resp. 5 (5.4110.1x.xxx)

Command TR

`<id>TR<para5>` Command for requesting a telegram (polling mode).
Description: Request of telegrams 4 to 10 (see CH. 7.3). If you want to get the data by polling, you should switch off the automatic mode with the command “`<id>TM00000`”. Otherwise the “TM” parameter will be set only internally to 0. If you wish to use the automatic mode again send the command “TM” or power up the sensor.
When a telegram is not available, the sensor answers “!`<id>TR00001`”.
Depending of the baudrate and the internal sensor clock a telegram is available
Availability:
Telegrams 6 to 10:
• 1200Bd: 0...57s
• \geq 2400Bd: 0...58s
Telegrams 4 and 5:
• 1200Bd: 0...38s
• 2400Bd: 0...49s
• 9600Bd/19.2kBd: 0...57s
• \geq 38.4kBd: 0...58s
Value range: 4...10
Initial value: -

Command TO

<id>TO</para5> Time for telegram 10 in minutes.
Description: Setting of the time for mean and extreme calculation as well as the time interval for automatic sending of telegram 10.
If using the automatic sending (command **<id>TM00010**) please consider the following:
It makes only sense to use 1 to 6 or 10 minutes, because otherwise the time interval is uneven. The automatic output take place at fixed times depending on the sensor clock (e.g. **<id>TO00010**: output at hh:00, hh:10, hh:20, hh:30, hh:40, hh:50).

Value range: 1...10
Initial value: 10

7.2.4 Time / Date commands

NOTE: For the operation the setting of date and time is not necessary. The date and time are reset when powered up, unless the UPS-input is provided. With the command "AZ" (CH. 7.2.6) the inaccuracy of the sensor clock can be corrected.

Command ZH

<id>ZH</para5> Setting the sensor clock (hour)
Description: Setting the hour. The sensor time can be requested by the command „ZT“.
Value range: 0...23
Initial value: 0

Command ZM

<id>ZM</para5> Setting the sensor clock (minute)
Beschreibung: Setting the minute. The sensor time can be requested by the command „ZT“
Value range: 0...59
Initial value: 0

Command ZS

<id>ZS</para5> Setting the sensor clock (second)
Description: Setting the second. The sensor time can be requested by the command „ZT“
Value range: 0...59
Initial value: 0

Command ZD

<id>ZD</para5> Setting the sensor date (day)
Description: Setting the day. The sensor date can be requested by the command „ZT“.
Value range: 1...31
Initial value: 1

Command ZN

<id>ZN<para5> Setting the sensor date (month)
Description: Setting the month. The sensor date can be requested by the command „ZT“
Value range: 1...12
Initial value: 1

Command ZY

<id>ZY<para5> Setting the sensor date (year)
Description: Setting the year. The sensor date can be requested by the command „ZT“
Value range: 0...99
Initial value: 5

Command ZT

<id>ZT Request of sensor date and clock
Description: Output of the sensor date and time.
Format: “TT.MM.JJ;HH:mm:SS” (example: “25.01.05;15:58:10”)
On resetting or activating the instrument the time is initialized with 00:00:00.
Value range: --
Initial value: (“01.01.05;00:00:00” set when power up without using UPS-input)

7.2.5 Diagnostics commands

Command DA

<id>DA Output of the optional measuring channels (5.4110.1x.xxx)
Description: Temperature/humidity: 30s-mean value (measurement every second)
Wind speed: 1s-mean value
Wind direction: instantaneous value (measurement every second)

column	Description
1-5	Temperature [°C]
7-11	Relative air humidity [%r.h.]
13-16	Wind speed [m/s]
18-20	Wind direction [°]

If a sensor is unavailable or the measuring range exceeded the value of the relevant column is “9”.

Example reply:

„-01.6;040.3;02.6;090“
(-1.6 °C temperature; 40.3 % relative humidity,
2.6 m/s wind speed, 90 ° wind direction)

Value range: -
Initial value: -

Command DD

<id>DD

Request of the diagnostic data

Description:

Number	Column	Description
1	1-3	Interior temperature [°C]
2	5-6	Temperature of laser driver 0-80°C
3	8-11	Mean value laser current [1/100 mA]
4	13-16	Control voltage [mV] reference value: 4010±5
5	18-21	Optical control output [mV] / control variable (2300 ... 6500)
6	23-25	Voltage sensor supply [1/10V] **
7	27-29	Current pane heating laser head [mA] **
8	31-33	Current pane heating receiver head [mA] **
9	35-39	Ambient temperature [°C] *
10	41-43	Voltage Heating supply [1/10 V] *
11	45-48	Current heating housing [mA] *
12	50-53	Current heating heads [mA] *
13	55-58	Current heating carriers [mA] *

* Variant 5.4110.x0.xxx: value always maximum

** Hardware Rev.A (see Figure 7) no measurement possible

Example reply (5.4110.x1.xxx, Variant „Extended Heating“):

„+01;08;1627;4011;2356;235;084;070;-06.4;233;0034;0845;2230“

- 1. +1°C Interior temperature
- 2. 8°C Temperature of laser driver
- 3. 16.27mA Mean value laser current
- 4. 4011mV Control voltage
- 5. 2356mV Optical control output
- 6. 23.5V Voltage sensor supply
- 7. 84mA Current pane heating laser head
- 8. 70mA Current pane heating receiver head
- 9. -6.4°C Ambient temperature
- 10. 23.3V Voltage Heating supply
- 11. 34mA Current heating housing
- 12. 845mA Current heating heads
- 13. 2230mA Current heating carriers

Value range: -

Initial value: -

Command DX

<id>DX

Description:

Requesting source of error, warning resp. condition of the lasers.

When an error or a warning has been detected the reason can be requested by means of this command.

„1“: error / warning

„0“: no error / warning

No.	Description	Error (E) Warning (W)
0	1: laser on 0: laser off	Status
1	Static signal out of allowed range	E
2	Laser temperature (analogue) too high	E
3	Laser temperature (digital) too high	E
4	Laser current (analogue) too high	E
5	Laser current (digital) too high	E
6	Sensor supply out of allowed range **	E
7	Current pane heating laser head **	W
8	Current pane heating receiver head **	W
9	Temperature sensor	W
10	Heating supply out of allowed range *	W
11	Current heating housing *	W
12	Current heating heads *	W
13	Current heating carriers *	W
14	Control output laser power high	W
15	Not used at the moment (0)	

* only applicable for variant 5.4110.x1.xxx, else value always “0”

** Hardware Rev.A (see Figure 7): always “0”

Example reply in case of no error :

„0;0;0;0;0;0;0;0;0;0;0;0;0;0;0“ (laser on, no error and warning detected)

Value range:

-

Initial value:

-

Command FM

<id>FM Output of error counter
Description: Output of the error counter 1 to 15 (number corresponds to "DX" command)

Note:

- Reset of error: see command "RF"
- The error counter is incremented when the error is no more present

Example reply:

„0005;0000;0000;0000;0000;0000;0002;0000;0000;0000;0000;0000;0000;0000“

5 times error 1: Static signal out of allowed range

2 times error 7: Current pane heating laser head

Value range: 0...9999

Initial value: 0

Command RF

<id>RF00001 Reset of error counters
Description: All error counters are set to 0.

Value range: 1

Initial value: -

Command HK,HB,HG

<id>HK<para5> Switch on/off head heatings
<id>HB<para5> Switch on/off carrier heatings
<id>HG<para5> Switch on/off housing heating

Description: With this commands the heating circuits can be switched on (parameter 1) for testing purpose (only 5.4110.x1.xxx). After one minute the respective circuit is switched off automatically. With the parameter 0 the circuit can be switched off immediately. Duty cycle should be at most 50% (at 20°C ambient temperature) or else overheating can occur.

Value range: 0,1

Initial value: -



**Attention: Head and carrier heatings could be hazardous hot!
Burn Hazard! (applies only for 5.4110.x1.xxx)**

Command ZB

<id>ZB Request of operating hours (resolution 2 hours)
Description: Output of the operating hours (resolution 2 hours) of the sensor.

Value range: 0...99999 (-> 22.8 years)

Initial value: 0

7.2.6 Calibration commands

Command AT

<id>AT	Alignment of the interior temperature
Description:	The interior temperature is necessary for the determination of the precipitation type (except for variant 5.4110.x1.xxx, see note below). With an outside temperature range from -4 to 10 °C the interior temperature should deviate by max. ± 2 °C (without solar radiation) . With solar radiation the difference can be up to 6 ± 2 °C. Please note: The alignment time with great temperature changes is (due to the compact housing) approx. 20 minutes. Parameter > 100 are negative. Example: AT00103 -> -3° temperature correction
Value range:	0...106
Initial value:	set in the factory

NOTE:

The variant 5.4110.x1.xxx ("Extended Heating") uses a Pt100-sensor at the bottom of the housing for the measurement of the ambient temperature. The interior temperature differs from the ambient about +5°C, if the heating is off (ambient temperature > 3°C)

Command AU

<id>AU	Request of the measuring area.
Description:	The measuring area is device-specific. Calculation of the area: $A_{\text{Meas}} = 4600\text{mm}^2 * 1000 / AU_{\text{Parameter}}$
Value range:	850...1200
Initial value:	set in the factory

Command AV

<id>AV<para5>	Adjusting measurement of quantity resp. intensity
Description:	Correcting precipitation quantity and intensity. Scaling in %.
Value range:	80 ... 120
Initial value:	100

Command AZ

<id>AZ Alignment of sensor clock
Description: Correction of clock accuracy. For standard requirements (accuracy approx. 10-20 minutes/year) no correction is necessary. In case of higher requirements the accuracy can be increased by this command.
As the clock accuracy depends on aging and temperature we recommend a correction after one year of operation.
Resolution of correction: 1 millisecond/minute = 1,44 seconds/day
Parameter > 100 are negative
Example: AT00105 -> -5ms/min (-7.2s/day) correction of clock
Value range: 0...123
Initial value: 105

7.2.7 Quantity measurement commands

Command RA

<id>RA00001 Reset of precipitation quantity and duration of quantity measurement.
Description: By this command the precipitation quantity, output in the telegram (parameter no. 17 in telegram 4 to 10, see CH. 7.3.1), is set to 0
Value range: 1
Initial value: -

Command PT

<id>PT Output of duration of quantity measurement.
Description: The duration of the quantity measurement is output in the format „H:M“ (H=hour, M=minute, max. 9999 hours). The duration is set to 0 by the command „RA“.
Note: no fixed number of signs
Value range: -
Initial value: -

7.2.8 Digital output commands

Command D1

<id>D1<para5> Setting the function of the digital output 1 (optocoupler)

Description:

Parameter	Description	Inactive (open)	Active (closed)	Frequency [Hz]
0	Always inactive	always	=====	=====
1	Sensor error active	No sensor error	Sensor error	=====
2	Sensor error inactive	Sensor error	No sensor error	=====
3	Sensor In operation	=====	=====	50
4	Sensor in operation + error	=====	=====	No error: 50 Sensor error: 1
5	Sensor in operation + precipitation+ error	=====	=====	No error: 50 precipitation: 10 Sensor error: 1
6	Sensor in operation + liquid precipitation + solid precipitation. + error	=====	=====	No error: 50 liquid precipitat.: 25 solid precip.: 10 sensor error: 1
7	precipitation active	No precipitation	precipitation	=====
8	precipitation inactive	precipitation	no precipitation	=====
9	liquid precipitation active	No liquid precipitation	liquid precipitation	=====
10	Liquid precipitation inactive	liquid precipitation	No liquid precipitation	=====
11	Solid precipitation active	No solid precipitation	Solid precipitation	=====
12	Solid precipitation inactive	Solid precipitation	No solid precipitation	=====
13	Precipitation quantity 0.1mm	=====	=====	10 (1impulse: 0.1mm)
14	Precipitation quantity 0.01mm	=====	=====	50 (1impulse: 0.01mm)
15	Precipitation quantity 0.005 mm	=====	=====	50 (1impulse: 0.005mm)
16	Always active	=====	always	=====
17	Precipitation type SYNOP(Tab.4680 , see Table 6) Frequency output 1	=====	=====	See the following Table 3
18	Precipitation quantity 0.1mm	=====	=====	1 (1Impulse: 0.1mm)
19	Precipitation type SYNOP(Tab.4680 , see Table 6) Frequency output 2	=====	=====	See the following Table 4

Value range: 0...19

Initial value: 13

No.	Frequency [Hz]	SYNOP (Tab.4680)	Description
0	1	-1	Sensor error
1	5	0	No precipitation
2	10	51	Light drizzle
3	20	52,53	Moderate / heavy drizzle
4	25	41,42	Unknown precipitation
5	33,33	57,61	Light drizzle with rain, Light rain
6	41,66	58,62,63	Moderate / heavy drizzle with rain, moderate / heavy rain
7	50	67	Light rain and / or drizzle with snow
8	62,5	68	Moderate / heavy rain and / or drizzle with snow
9	83,33	77	Snow grains
10	100	71	Light snow fall
11	125	72,73	Moderate / heavy snow fall
12	166,67	74,75,76	Soft hail / ice grains
13	250	89	Hail

Table 3: Parameter 17 (command D1 and D2)

Nr	Frequency [Hz]	SYNOP (Tab.4680)	Description
0	1	-1	Sensor error
1	2,5	41	Light / moderate unknown precipitation
2	5	42	Heavy unknown precipitation
3	10	0	No precipitation
4	15,15	51	Light drizzle
5	20	52	Moderate drizzle
6	22,73	53	Heavy drizzle
7	25	57	Light drizzle with rain
8	29,41	58	Moderate / heavy drizzle with rain
9	33,33	61	Light rain
10	38,46	62	Moderate rain
11	41,66	63	Heavy rain
12	45,45	67	Light rain and / or drizzle with snow
13	50	68	Moderate / heavy rain and / or drizzle with snow
14	55,56	77	Snow grains
15	62,5	71	Light snow fall
16	71,43	72	Moderate snow fall
17	83,33	73	Heavy snow fall
18	100	74	Light soft hail / ice grains
19	125	75	Moderate soft hail / ice grains
20	166,67	76	Heavy soft hail / ice grains
21	250	89	Hail

Table 4: Parameter 19 (command D1 and D2)

Note:

- Frequency output changes every minute
- The reported precipitation type „Unknown precipitation“ is a error code. See for this the notes in Table 6: Code table SYNOP / METAR.

Command D2

<id>D2<para5> Setting the function of the digital output 2 (opto-coupler).
Description: see command „D1“
Value range: 0...19
Initial value: 19

Telegram 5 : Synop, Metar, Disdrometer , optional measuring channel („<id>tm00005“)

In addition to the output given above telegram the optional measuring channels are output at the end (see also command “DA”, CH. 7.2.5)

No.	Column	Len	Description	
1	1	1	STX (start identifier)	
2	2-3	2	Device address (factory setting „00“) (NN)	
3	5-8	4	Serial number (NNNN)	
4	10-13	5	Software-Version (N.NN)	
5	15-22	8	Date of the sensor (tt.mm.jj)	
6	24-31	8	Time of the sensor (on request) (hh:mm:ss)	
7	33-34	2	5M SYNOP Tab.4677 (5 minutes mean value) (NN)	
8	36-37	2	5M SYNOP Tab.4680 (5 minutes mean value) (NN)	
9	39-43	5	5M METAR Tab.4678 (5 minutes mean value) (AAAAA)	
10	45-51	7	5M Intensität [mm/h] (5 minutes mean value) (NNN.NNN)	
11	53-54	2	1M SYNOP Tab.4677 (1 minute value) (NN)	
12	56-57	2	1M SYNOP Tab.4680 (1 minute value) (NN)	
13	59-63	5	1M METAR Tab.4678 (1 minute value) (AAAAA)	
14	65-71	7	1M Intensity [mm/h] total precipitation (1 minute value) (NNN.NNN)	*
15	73-79	7	1M Intensity [mm/h] liquid precipitation (1 minute value) (NNN.NNN)	**
16	81-87	7	1M Intensity [mm/h] solid precipitation (1 minute value) (NNN.NNN)	**
17	89-95	7	Precipitation amount [mm] (Reset with command „RA“) (NNNN.NN)	
18	97-101	5	1M Visibility in precipitation [0...99999m] (1 minute value) (NNNNN)	***
19	103-106	4	1M Radar reflectivity [-9.9...99.9dBZ] (1 minute value) (NN.N)	*4
20	108-110	3	1M Measuring quality [0...100%] (1 minute value) (NNN)	*5
21	112-114	3	1M Maximum diameter hail [mm] (1 minute value) (N.N)	
22	116	1	Status Laser (OK/on:0, off:1)	*9
23	118	1	Static signal (OK:0, Error:1)	*9
24	120	1	Status Laser temperature (analogue) (OK:0, Error:1)	*9
25	122	1	Status Laser temperature (digital) (OK:0, Error:1)	*9
26	124	1	Status Laser current (analogue) (OK:0, Error:1)	*9
27	126	1	Status Laser current (digital) (OK:0, Error:1)	*9
28	128	1	Status Sensor supply (OK:0, Error:1)	*9
29	130	1	Status Current pane heating laser head (OK:0, warning:1)	*9
30	132	1	Status Current pane heating receiver head (OK:0, warning:1)	*9

31	134	1	Status Temperature sensor (OK:0, warning:1)	*9
32	136	1	Status Heating supply (OK:0, warning:1)	*9
33	138	1	Status Current heating housing (OK:0, warning:1)	*9
34	140	1	Status Current heating heads (OK:0, warning:1)	*9
35	142	1	Status Current heating carriers (OK:0, warning:1)	*9
36	144	1	Status Control output laser power (OK:0, warning:1)	*9
37	146	1	Reserve Status (0)	*9
38	148-150	3	Interior temperature [°C] (NNN)	*10
39	152-153	2	Temperature of laser driver 0-80°C (NN)	*10
40	155-158	4	Mean value laser current [1/100 mA] (NNNN)	*10
41	160-163	4	Control voltage [mV] (reference value: 4010±5) (NNNN)	*10
42	165-168	4	Optical control output [mV] (2300 ... 6500) (NNNN)	*10
43	170-172	3	Voltage sensor supply [1/10V] (NNN)	*10
44	174-176	3	Current pane heating laser head [mA] (NNN)	*10
45	178-180	3	Current pane heating receiver head [mA] (NNN)	*10
46	182-186	5	Ambient temperature [°C] (NNN.N)	*10
47	188-190	3	Voltage Heating supply [1/10 V] (only 5.4110.x1.xxx, otherwise "999") (NNN)	*10
48	192-195	4	Current heating housing [mA] (only 5.4110.x1.xxx, otherwise "9999") (NNNN)	*10
49	197-200	4	Current heating heads [mA] (only 5.4110.x1.xxx, otherwise "9999") (NNNN)	*10
50	202-205	4	Current heating carriers [mA] (only 5.4110.x1.xxx, otherwise "9999") (NNNN)	*10
51	207-211	5	Number of all measured particles (NNNNN)	
52	213-221	9	„00000.000“ (internal data)	
53	223-227	5	Number of particles < minimal speed (0.15m/s) (NNNNN)	
54	229-237	9	„00000.000“ (internal data)	
55	239-243	5	Number of particles > maximal speed (20m/s) (NNNNN)	
56	245-253	9	„00000.000“ (internal data)	
57	255-259	5	Number of particles < minimal diameter (0.15mm) (NNNNN)	
58	261-269	9	„00000.000“ (internal data)	
59	271-275	5	Number of particles no hydrometeor	*6
60	277-285	9	Total volume (gross) of this class	*6
61	287-291	5	Number of particles with unknown classification	*6
62	293-301	9	Total volume (gross) of this class	*6
63	303-307	5	Number of particles class 1	*6
64	309-317	9	Total volume (gross) of class 1	*6
65	319-323	5	Number of particles class 2	*6
66	325-333	9	Total volume (gross) of class 2	*6

67	335-339	5	Number of particles class 3	*6
68	341-349	9	Total volume (gross) of class 3	*6
69	351-355	5	Number of particles class 4	*6
70	357-365	9	Total volume (gross) of class 4	*6
71	367-371	5	Number of particles class 5	*6
72	373-381	9	Total volume (gross) of class 5	*6
73	383-387	5	Number of particles class 6	*6
74	389-397	9	Total volume (gross) of class 6	*6
75	399-403	5	Number of particles class 7	*6
76	405-413	9	Total volume (gross) of class 7	*6
77	415-419	5	Number of particles class 8	*6
78	421-429	9	Total volume (gross) of class 8	*6
79	431-435	5	Number of particles class 9	*6
80	437-445	9	Total volume (gross) of class 9	*6
81	447-449	3	From here (447) to the end(2205): precipitation spectrum (distrometer data) (NNN) Number of particles 0.125mm<diameter <0.25mm and speed <0.2m/s	*7
...	3	Remaining 439 classes (first all speeds, then the next diameter class , see Table 5: Disdrometer class binning below)	*7
520	2203- 2205	3		
521	2207- 2208	2	Checksum (not with "<id>TM00005") (AA)	*8
522	2210- 2211	2	CRLF (not with "<id>TM00005")	
523	2212	1	ETX (End identifier) ((not with "<id>TM00005")	

Additionally with "<id>TM00005":

521	2207-2211	5	Temperature [°C] (NNN.N)	*11
522	2213-2217	5	Relative Air humidity [%r.h.] (NNN.N)	*11
523	2219-2222	4	Wind speed [m/s] (NN.N)	*11
524	2224-2226	3	Wind direction [°] (NNN) (*11
525	2228-2229	2	Checksum (AA)	*8
526	2231-2232	2	CRLF	
527	2233	1	ETX (End identifier)	

* Total intensity is calculated with the adding of parameter 15 and 16.
Exception: when „not identified precipitation“ is reported (15+16 are then 0)

** Raw value

*** Calculation visibility MOR in precipitation:

$$V_{\text{MOR}}(\text{Prec}) = 3,0 / (\pi/2 * 1/(A * t) * \sum (D_i^2 / V_i)) \quad [\text{m}]$$

A: Measuring area sensor [m²] (Note: device-specific, see command “AU”, CH. 7.2.6)

t: Measuring time (60 s)

D_i: Diameter of one particle [m]

V_i: Velocity of one particle [m/s]

NOTE:

“Visibility in precipitation” is the maximum visibility. Depending on the humidity (e.g. fog) and other particle in the atmosphere the real visibility is lower. Only atmospheric hazes, caused by big hydro-meteors (for ex. drizzle, rain, snow) are acquired, but not by small hydro-meteors (fog, damp), and aerosols.

Calculated is the meteorological optical range MOR (contrast 5%, -LN(0,05)=3,0). When you want to get the “normal” visibility (contrast 2%, -LN(0,02)=3,91), you have to multiply the value by 1,304 (=3,91/3,0).

*4 Calculation Radar reflectivity

$$Z = 10 \text{ LOG}_{10} (1/(A * t) * \sum (|K_i|^2 / |K_w|^2 * D_i^6 / V_i)) \quad [\text{dB mm}^6/\text{m}^3]$$

A: Measuring area sensor [m²] (Note: device-specific, see command “AU”, CH. 7.2.6)

t: Measuring time (60 s)

|K_i|²: Dielectric factor of one particle (Water: 0,93 , Snow: 0,208)

|K_w|²: Dielectric factor of Water (0,93)

D_i: Diameter of one particle [mm]

V_i: Velocity of one particle [m/s]

*5 Measuring quality:

This value indicates the significance of the precipitation classification (parameter 11,12 and 13). The sensor analyse for this value the quantity of the particles and the measured ambient temperature. It should be considered that other factors (e.g. wind speed, dense fog) can decrease the measuring quality provided by the instrument.

*6 Internal data (raw values).

*7 The particle spectrum are raw data. Obvious illogical measurements (e.g. particle no hydrometeor, snow-particle when temperature is greater than 8°C) should if necessary removed.

*8 Calculation checksum:

The two's complement of the sum of all characters (alpha-numeric and control character like STX / ETX / CR / LF), but not the checksum, is calculated. Given out is from the least significant byte (LSB) the high- and low-nibble (half-byte) in two characters in hexadecimal ASCII-code.

Example:	Sum decimal:	64800
	Sum hexadecimal:	0FD20
	2's complement(Hex):	F02E0
	LSB Byte(Hex):	E0
	Output(ASCII):	"E0"

*9 see also command „DX“, CH. 7.2.5

*10 see also command „DD“, CH. 7.2.5

*11 see also command „DA“, CH. 7.2.5

Particle diameter class		
Class	Diameter [mm]	Class width [mm]
1	≥ 0.125	0.125
2	≥ 0.250	0.125
3	≥ 0.375	0.125
4	≥ 0.500	0.250
5	≥ 0.750	0.250
6	≥ 1.000	0.250
7	≥ 1.250	0.250
8	≥ 1.500	0.250
9	≥ 1.750	0.250
10	≥ 2.000	0.500
11	≥ 2.500	0.500
12	≥ 3.000	0.500
13	≥ 3.500	0.500
14	≥ 4.000	0.500
15	≥ 4.500	0.500
16	≥ 5.000	0.500
17	≥ 5.500	0.500
18	≥ 6.000	0.500
19	≥ 6.500	0.500
20	≥ 7.000	0.500
21	≥ 7.500	0.500
22	≥ 8.000	∞

Particle speed class		
Class	Speed [m/s]	Class width [m/s]
1	≥ 0.000	0.200
2	≥ 0.200	0.200
3	≥ 0.400	0.200
4	≥ 0.600	0.200
5	≥ 0.800	0.200
6	≥ 1.000	0.400
7	≥ 1.400	0.400
8	≥ 1.800	0.400
9	≥ 2.200	0.400
10	≥ 2.600	0.400
11	≥ 3.000	0.400
12	≥ 3.400	0.800
13	≥ 4.200	0.800
14	≥ 5.000	0.800
15	≥ 5.800	0.800
16	≥ 6.600	0.800
17	≥ 7.400	0.800
18	≥ 8.200	0.800
19	≥ 9.000	1.000
20	≥ 10.000	10.000

Table 5: Disdrometer class binning of diameter and speed

Type of Precipitation	Internal	NWS Code	SYNOP ww Tab.4677	METAR/SPECI w'w' Tab.4678	SYNOP w _a w _a Tab.4680
Sensor error	0		-1 [*]	????? ^{**}	-1 [*]
No precipitation	1	C	00	NP	00
Precipitation (not identified ^{****})	2	P-,P,P+	-2,-3,-4 [*]	-UP,UP,+UP	41,41,42
Drizzle (also freezing ^{***})	3	L-,L,L+	51,53,55	-DZ,DZ,+DZ	51,52,53
Freezing drizzle (see drizzle ^{***})	3	[ZL] L-,L,L+	[56,57,57] 51,53,55	[FZDZ] -DZ,DZ,+DZ	[54,55,56] 51,52,53
Drizzle with rain (also freezing ^{***})	4	RL-, RL,RL+	58,59,59	-RADZ, RADZ,+RADZ	57,58,58
Rain (also freezing ^{***})	5	R-,R,R+	61,63,65	-RA,RA,+RA	61,62,63
Freezing rain (see rain ^{***})	5	[ZR] R-,R,R+	[66,67,67] 61,63,65	[FZRA] -RA,RA,+RA	[64,65,66] 61,62,63
Rain and/or drizzle with snow	6	RLS-,RLS, RLS+	68,69,69	-RASN, RASN,+RASN	67,68,68
Snow	7	S-,S,S+	71,73,75	-SN,SN,+SN	71,72,73
Ice pellets (see soft hail ^{***})	9	[IP] SP	[79] 87,88,88	[PE/PL] GS	74,75,76
Snow grains (also ice prisms ^{***})	8	SG	77	-SG,SG,+SG	77
Ice crystals /-needles (see snow grains ^{***})	8	[IC] SG	[76] 77	[IC] SG	[78] 77
Soft hail (also ice pellets ^{***})	9	SP	87,88,88	-GS,GS,+GS	74,75,76
Hail	10	A	89,90,90	GR	89

Table 6: Code table SYNOP / METAR

* Code comply not with table 4677 / 4680

** Code comply not with table 4678

*** Definitions of table 4677/4678/4680 were not meet by liquid precipitation (determination freezing / not freezing), determination soft hail / ice pellets and snow grains / ice prism.

**** If this precipitation type is often detected, the sensor should be cleaned. Normally natural reasons (e.g. spider web) are responsible for this behaviour. This report should be managed as a error, therefore we recommend to not use this precipitation type and the intensity. In the same way the precipitation types drizzle and snow grains should not observed until the disturbance is eliminated, because they could be erroneous.

[...] Not identifiable / reference value i.e. code in brackets will be not transmitted.

SYNOP intensities [mm/h]	Light	Moderate	Heavy
Drizzle	≤ 0,2	> 0,2 ... 0,5	> 0,5
Rain, snow, unknown precipitation, sleet, drizzle with rain	≤ 0,5	> 0,5 ... 4,0	> 4,0
Ice pellets, soft hail	≤ 2,4	> 2,4 ... 12,0	> 12,0
Hail (only Tab.4677)	Particle < 8mm	Particle ≥ 8mm	

Table 7: Intensity steps SYNOP

NWS/METAR/SPECI intensities [mm/h] [(inch/h)]	Light	Moderate	Heavy
Drizzle	≤ 0,25 (≤ 0,01)	>0,25 ... 0,5	>0,5 (>0,02)
Rain, precipitation, drizzle with rain, sleet	≤ 2,5 (≤ 0,1)	>2,5 ... 7,6	>7,6 (>0,3)
Snow ,soft hail, snow grains Ice pellets	≤ 1,25 (≤ 0,05)	>1,25 ... 2,5	>2,5 (>0,1)

Table 8: Intensity steps METAR

7.3.2 Telegram 6/7: Synop, Metar, optional measuring channel

This telegram is transmitted every minute by the instrument (without request of receiver), when the parameter “TM” (CH. 7.2.3) is 6 or 7 (automatic mode). The request of the telegram (polling mode) is possible with the command „<id>TR00006“ (or „<id>TR00007“).

List separator: ; (Semicolon)

Decimal separator: . (Point)

Start of telegram: STX(02)

End of telegram: CR(13), LF(10), ETX(03) (carriage return, line feed, ETX)

Fixed length and leading zeros.

Error code / data not available: output of the greatest presentable number (e.g. “99.9”)

Example telegram 6:

```
00;0999;2.00;11.02.05;10:48:00;00;00;NP ;004.047;75;73;+SN
;020.234;000.000;020.234;0000.34;00319;66.7;100;0.0;0;0;0;0;0;0;0;0;0;0;0;0;1;0;0;0;0;+19;28;1626;4011;234
6;236;085;068;+04.6;000;0000;0000;0000;00044;C7;
```

Telegram 7: Synop, Metar, optional Measuring Channels

In addition to the output given above telegram 6 the optional measuring channels are output at the end (see also command “DA”, CH. 7.2.5)

Example :

```
00;0999;2.00;11.02.05;10:50:56;00;00;NP ;004.047;00;00;NP
;000.000;000.000;000.000;0000.34;99999;-
9.9;100;0.0;0;0;0;0;0;0;0;0;0;0;0;0;1;0;0;0;0;+19;28;1627;4010;2344;236;084;068;+04.6;000;0000;0000;0000;0
0000;+04.6;99999;00.0;999;C2;
```

No.	Column	Len	Description	
1	1	1	STX (start identifier)	*
...		*
51	207-211	5	Number of all measured particles (NNNNN)	*
52	213-214	2	Checksum (not with „<id>TM00007“) (AA)	**
53	216-217	2	CRLF (not with „<id>TM00007“)	
54	218	1	ETX (End identifier) (not with „<id>TM00007“)	

Additionally with telegram 7:

No.	Column	Len	Description	
52	213-217	5	Temperature [°C] (NNN.N)	***
53	219-223	5	Relative Air humidity [%r.h.] (NNN.N)	***
54	225-228	4	Wind speed [m/s] (NN.N)	***
55	230-232	3	Wind direction [°] (NNN)	***
56	234-235	2	Checksum (AA)	**
57	237-238	2	CRLF	
58	239	1	ETX (End identifier)	

* Parameter accordant to telegram 4 und 5 (see CH. 7.3.1)

** Calculation correspondent to telegram 4 und 5 (see CH. 7.3.1)

*** Parameter correspondent to command „DA“ (see CH. 7.2.5)

7.3.3 Telegram 8/9: Synop, Metar, optional measuring channel truncated

This telegram is transmitted every minute by the instrument (without request of receiver), when the parameter "TM" (CH. 7.2.3) is 8 or 9 (automatic mode). The request of the telegram (polling mode) is possible with the command „<id>TR00008“ (or „<id>TR00009“).

List separator: ; (Semicolon)

Decimal separator: . (Point)

Start of telegram: STX(02)

End of telegram: CR(13), LF(10), ETX(03) (carriage return, line feed, ETX)

Fixed length and leading zeros.

Error code / data not available: output of the greatest presentable number (e.g. "99.9")

Example telegram 8:

```
61;0000;2.30;01.01.07;18:36:00;00;00;NP ;000.000;00;00;NP  
;000.000;000.000;000.000;0000.00;99999;-9.9;100;0.0;ED;
```

Telegram 9:

In addition to the output given above telegram 8 the optional measuring channels are output at the end (see also command "DA", CH. 7.2.5)

Example Telegram 9:

61;0000;2.30;01.01.07;18:43:00;00;00;NP ;000.000;00;00;NP
;000.000;000.000;000.000;0000.00;99999;-9.9;100;0.0;99999;99999;9999;999;3A;

No.	Column	Len	Description	
1	1	1	STX (start identifier)	*
...		*
21	112-114	3	1M Maximum diameter hail [mm] (1 minute value) (N.N))	*
22	116-117	2	Checksum (not with „<id>TM00007“) (AA)	**
23	119-120	2	CRLF (not with „<id>TM00007“)	
24	121	1	ETX (End identifier) (not with „<id>TM00007“)	

Additionally with telegram 9:

No.	Column	Len	Description	
22	116-120	5	Temperature [°C] (NNN.N)	***
23	122-126	5	Relative Air humidity [%r.h.] (NNN.N)	***
24	128-131	4	Wind speed [m/s] (NN.N)	***
25	133-135	3	Wind direction [°] (NNN)	***
26	137-138	2	Checksum (AA)	**
27	140-141	2	CRLF	
28	142	1	ETX (End identifier)	

* Parameter accordant to telegram 4 und 5 (see CH. 7.3.1)

** Calculation correspondent to telegram 4 und 5 (see CH. 7.3.1)

*** Parameter correspondent to command „DA“ (see CH. 7.2.5)

7.3.4 Telegram 10: Synop, Metar, optional measurement channels, averaging

This telegram is transmitted by the instrument automatically in case the parameter “TM (chap.7.2.3.) is set to 10. The time interval for automatic transmission and the averaging period is set through command “TO” (chap.7.2.3.)

The query of the telegram is carried out in the polling mode through command “<id>TR00010”.

Separator : (semicolon)

Decimal separator : (point)

Telegram start STX(02)

Telegram end: CR(13), LF(10), ETX(03) (carriage return, line feed, ETX)

Fix lengths and leading zeros

Error recognition:: biggest presentable number is output, in case no data are available (for ex. 99.9)

:

Example telegram 10:

```
00;0999;2.40;02.01.07;10:40:00;00;00;NP  
;000.000;00;00;NP;000.000;000.000;000.000;0000.00;99999;-  
9.9;100;0.0;0;0;0;0;0;0;0;0;0;0;0;0;0;0;+19;28;1626;4010;2384;235;090;070;99999;999;9999;99  
99;9999;00000;99999;99999;9999;999;04;002.675;005.900;61;00;00;75;61;62;51;61;61;61;51;F4;
```

No	column	Length	Description	
1	1	1	STX (start identification)	*
...		*
55	230-232	3	wind direction [°] (NNN)	*
56	234-235	2	Averaging period in minutes (NN) (setting command „TO“ -)	
57	237-243	7	Mean intensity in the averaging period in mm/h (NNN.NNN)	
58	245-251	7	Maximum 1-min-intensity in the averaging period in mm/h (NNN.NNN)	
59	253-254	2	Macimum value SYNOP Tab.4680 in the averaging period (NN)	
60	256-257	2	1M SYNOP Tab.4680 transmission time-9 minutes (1-minute value) (NN)	
61	259-260	2	1M SYNOP Tab.4680 transmission time-8 minutes (1-minute value) (NN)	
62	262-263	2	1M SYNOP Tab.4680 transmission time-7 minutes (1-minute value) (NN)	
63	265-266	2	1M SYNOP Tab.4680 transmission time-6 minutes (1-minute value) (NN)	
64	268-269	2	1M SYNOP Tab.4680 transmission time-5 minutes (1-minute value) (NN)	
65	271-272	2	1M SYNOP Tab.4680 transmission time-4 minutes (1-minute value) (NN)	
66	274-275	2	1M SYNOP Tab.4680 transmission time-3 minutes (1-minute value) (NN)	
67	277-278	2	1M SYNOP Tab.4680 transmission time-2 minutes (1-minute value) (NN)	
68	280-281	2	1M SYNOP Tab.4680 transmission time-1 minute (1-minute value) (NN)	
69	283-284	2	1M SYNOP Tab.4680 transmission time (1-minute value) (NN)	**
70	286-287	2	Checksum (AA)	***
71	289-290	2	CRLF	
72	291	1	ETX (end identification)	

* Parameter acc. to telegram 7 (see chap.7.3.2.)

** Corresponds to value no. 12 (column 56 and 57) of the telegram

*** Calculation acc. to telegram 4 and 5 (see chap. 7.3.1)

7.3.5 Telegram 3: Particle-Event

The instrument transmits (without request of the receiver) this telegram with every event (particle falling through the measuring area). Output of all measured particles with higher precipitation intensities is not guaranteed. The command to set this telegram is "<id>TM00003" (see CH. 7.2.3).

List separator: ; (Semicolon)
Decimal separator: . (Point)
End of telegram: CRLF (Carriage return + Line Feed)

NOTE:

We do not recommend to use this telegram with communication in half-duplex-mode (command "BD", see CH. 7.2.1), because of the autonomous transmitting of the sensor .

Preferably use high baud rate

No.	Description
1	Maximal value of A/D-converter [0...16383]
2	Duration of event [10µs]
3	Time stamp (0...4,294,967,295) [ms]
4	Diameter sphere [mm]
5	Speed sphere [m/s]
6	Diameter "Hamburger"(rain) [mm] *
7	Speed "Hamburger" (rain) [m/s] *
8	Internal Temperature [°C]

* "Hamburger"-shape: Only very small raindrops with diameters well below 1 mm will be perfect spheres due to their high surface tension. Larger drops tend to be flattened, leading to oblate shapes ("Hamburger"). For this reason use this values for rain particles.

Example: 14764;8728;493413279;7.01;00.09;5.75;00.08;+19

Diameter sphere: 7.01 mm

Speed sphere: 00.09 m/s

8 Technical Data

General:	
Ambient conditions	-40... +70 °C, 0... 100% r.h.
Maximum altitude	<1500m MSL (for greater heights please refer to the manufacturer)
Dimensions	0,27 x 0,17 x 0,54 m 10.63 x 6.7 x 21.3 inch (w/o mast holder)
Weight	4.8 kg (5.4110.x0.xxx) 6.5 kg (5.4110.x1.xxx) ("Extended Heating"-variant)
Housing electronics	Aluminium die-casting, varnished
Housing sensors	Aluminium (anodised)
Protection	IP65
Maintenance	Automatic soil-recognition for cleaning the optics
EMC Immunity	EN61326 in conjunction with EN61000-4-3 10V/m (5.4110.x1.xxx: 7V/m (10V/m)) EN61000-4-4 level 4 (power line $\pm 4\text{kV}$, signal line $\pm 2\text{kV}$) EN61000-4-5 level 4 (power line $\pm 2\text{kV}_{\text{symmetric}}$ $\pm 4\text{kV}_{\text{asymmetric}}$, signal line $\pm 2\text{kV}_{\text{symmetric}}$) EN61326 class B
Radiation	
Mounting	Mast mounting (\varnothing 48... 102mm, 1.9... 4 inch) Stainless steel
Power supply:	
5.4110.x0.0xx: Supply voltage (heating + electronics) Max. current consumption 24V~/= AC/DC-input Note: supply must be potential-free	24V~ AC +15% -30% / 20...30V= DC 750mA
5.4110.x1.0xx: Supply voltage (heating + electronics) Max. current consumption 24V~/= AC/DC-input Supply voltage Extended Heating Max. current consumption Extended Heating Note: Both supplies must be potential-free, also among each other.	24V~ AC +15% -30% / 20...30V= DC 750mA 26V~ AC $\pm 15\%$ / 22...30V= DC 6.3A

5.4110.x0.1xx: Supply voltage AC (heating + electronics) Maximum power consumption	115V~ AC +10% -25% 15 VA
5.4110.x1.1xx: supply voltage AC (heating + electronics) Maximum power consumption	115V~ AC +10% -25% 150VA
5.4110.x0.2xx: Supply voltage AC (heating + electronic) Maximum power consumption	230V~ AC +10% -25% 15 VA
5.4110.x1.2xx: Supply voltage AC (heating + electronic) Maximum power consumption	230V~ AC +10% -25% 150 VA
5.4110.x0.3xx: Supply voltage DC (heating + electronic) Maximum current consumption 12V..24V= DC Note: supply must be potential-free	12 ... 24V= DC \pm 10% <550mA(12V=) <500mA(24V=)
Buffer input / UPS-operation (all variants except for 5.4110.xx.3xx): Supply voltage DC (only electronics) Current consumption DC input (only electronics) Note: supply must be potential-free Applies for all models except 5.4110.xx.3xx	12 ... 24V= DC \pm 10% < 150mA (12V=) < 75mA (24V=)
Heating:	
Glass pane heating	2.5W each (with temperature regulation)
Option: heating for extreme conditions (5.4110.x1.xxx)	The heating is controlled in dependency on the ambient temperature. Laser-/Receiver-Head: 9W each Carriers: 27W each Housing: 20W
Sensors: Laser diode Laser class Modulation frequency Photo diode Measuring area	785nm, max. 0,5mW optical power Laser class 1M (EN 60825-1:1994 A2: 2001) 172.8 KHz with day light filter (< 700nm) 40...47 cm ² (instrument-specific) 7.067inch ² (8.98 x 0.787 inch)

Ambient temperature sensor	NTC (5.4110.x0.xxx) Pt100 (5.4110.x1.xxx , measurement current < 0.8 mA))
Electronics for evaluation:	
Digital signal processor	TMC320VC33 (55.3 MHz)
RAM-memory	136KB
Flash-memory	256KB (for firmware and parameter, to be uploaded via serial interface) No. of changes: 1 million
14Bit-A/D-converter	scanning 109 KHz (for optical measuring signal)
12Bit-A/D-converter	For self diagnosis and optional measuring input
Data output:	
RS485/RS422	Potential isolation up to 1KV 1200,2400,4800,9600,19200,38400,57600,115200 Bd 7 / 8 data bits, parity none(N) / even(E) / odd(O) 1 / 2 stop bits full-duplex (4-wire) or half-duplex (2-wire), latency time 20ms (half-duplex) terminator resistor (560Ω) switch able
Digital output	2 optocouplers (max. 24VDC, max. 1mA) Potential isolation up to 1KV Function selectable

Precipitation:	
Particle size (effective) **	0,16 ... >8 mm Ø
Particle speed	0,2 ... 20 m/s
Identification of precipitation types: -drizzle(DZ), freezing drizzle (FZDZ) -rain(RA), freezing rain (FZRA) -hail(GR) -snow (SN) -snow grains (SG), ice needles(IC) -soft hail(GS), ice grains(PL)	Hit rate (compared with synoptic observation), wind speed < 3m/s) >97% (Intensity > 0.01 mm/h) >99% (>= 2 particles/min, no solid precipitation) >95% (>= 2 particles/min) >99% (no mixed precipitation) >60 % t.b.d.
Output Precipitation Type	SYNOP (Tab.4677 + 4680), METAR (Tab.4678)
Error intensity-/quantity measurement (rain equivalent) compared with reference sensor (wind speed< 3m/s)	≤ 15% (rain, 0,5... 20mm/h) ≤ 30% (snow)

Minimum Intensity (depending on precipitation type)	< 0,005 mm/h (drizzle)
Maximum Intensity	> 250 mm/h
Visibility MOR in precipitation	0 ... 99999 m
Radar reflectivity	-9.9 ... 99.9 dBZ
Disdrometer classes	440 classes (22 diameter * 20 speed)
Option Measuring Inputs: 5.4110.1x.xxx	
Temperature (Pt100) (not available for variant 5.4110.11.xxx)	Meas. range: -40... 70°C Accuracy: ±0.1°C (measuring input)
Relative humidity (0-1V)	Meas. range: 0 ... 100 % r. h. Accuracy: ±0.1% (meas. range)
Wind Speed (Thies Compact, e.g. 4.3519.00.000)	Meas. range: 0 ... 60 m/s Accuracy: ±0.1m/s (measuring input)
Wind direction (Thies Compact, e.g. 4.3129.00.000)	Meas. range: 0 ... 360°
Accessories (Optional):	
Visualisation software LPM View (9.1700.99.000)	For Windows operating systems (Win98(SE), WinMe, Win2000, XP).
Instrument Support (4.3187.60.200) For the vibration-reduced operation of the LPM at 2 m height on an available concrete foundation, provided by the customer.	Tube length: 2 m Tube diameter: 60 mm Weight: 30 Kg Material: Steel, hot-dip galvanized

Alteration of technical data reserved

* Supply must be potential-free, or the negative voltage is on the same potential as the housing of the sensor (protective earth). This UPS-supply ("uninterruptible power supply") allows a restricted operation (no heating) of the sensor whenever the normal supply falls out.

** Applies for liquid and solid particles like rain, pellets/graupel and hail. For snow flakes by reason of the less optical extinction a greater maximum diameter can be assumed.

*** Visibility in the precipitation: Only atmospheric hazes caused by big hydro-meteors (for ex. drizzle, rain, snow) are acquired.

9 Wiring Diagram



ATTENTION: Do not look into the invisible laser beam!

Wiring Diagram Supply:

Note: Wiring diagram communication see following page.

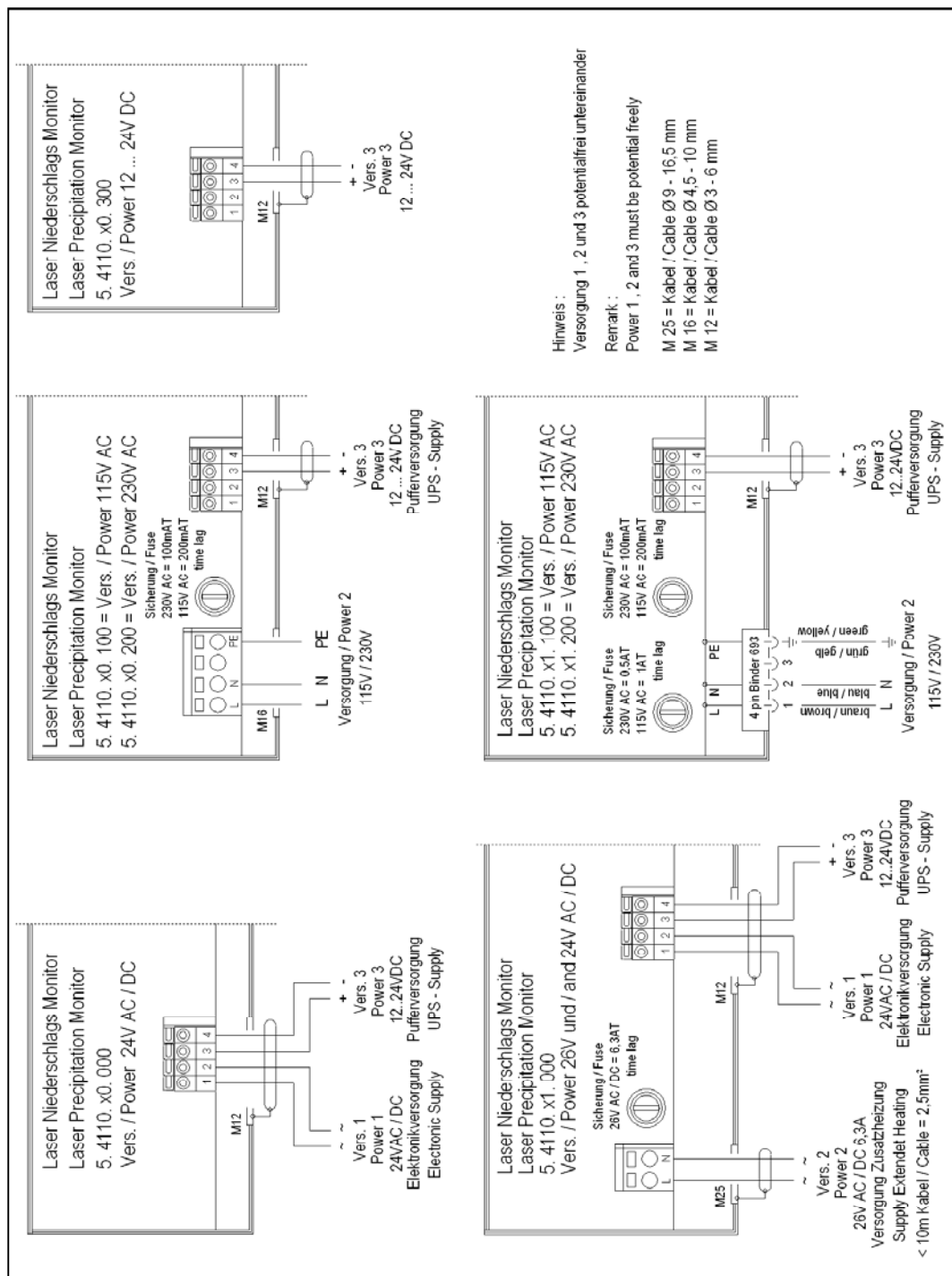

Hinweis :
 Versorgung 1, 2 und 3 potentialfrei untereinander
 Remark :
 Power 1, 2 and 3 must be potential freely
 M 25 = Kabel / Cable Ø 9 - 16,5 mm
 M 16 = Kabel / Cable Ø 4,5 - 10 mm
 M 12 = Kabel / Cable Ø 3 - 6 mm



Attention: *Head and carrier heating could be hazardous hot!
Burn Hazard! (applies only for 5.4110.x1.xxx)*

NOTE:

Run all supply cables in the housing through the delivered ferrite tube! (see Figure 12, applies not for variant 5.4110.x1.xxx)

Power input 1(24V AC/DC) and 3 (12..24 V DC) must be potential-free, or the negative voltage is on the same potential as the housing of the sensor (protective earth).

This UPS-supply (Power 3) allows a restricted operation (no heating) of the sensor whenever the normal supply falls out. (Applies not for variant 5.4110.xx.3xx)

10 Declaration of Conformity

Document-No.: **000904**

Month: 03 Year: 07

Manufacturer: **ADOLF THIES GmbH & Co. KG**

Hauptstr. 76
D-37083 Göttingen
Tel.: (0551) 79001-0
Fax: (0551) 79001-65
email: Info@ThiesClima.com

Description of Product: **Laser-Niederschlags-Monitor**

Article No.	5.4110.00.000	5.4110.00.100	5.4110.00.200	5.4110.00.300
	5.4110.10.000	5.4110.10.100	5.4110.10.200	5.4110.10.300
	5.4110.01.000	5.4110.11.000	5.4110.01.100	5.4110.11.100
	5.4110.01.200	5.4110.11.200		

specified technical data in the document: **021340/02/07**

The indicated products correspond to the essential requirement of the following European Directives and Regulations:

89/336/EEC	COUNCIL DIRECTIVE of 3 May 1989 on the approximation of the laws of the Member States relating to electromagnetic compatibility (89/336/EEC)
73/23/EEC	COUNCIL DIRECTIVE of 19. Feb.1973 on the harmonization of the law of Member States relating to electrical equipment designed for use within certain voltage limits (73/23/EEC)
552/2004/EC	Regulation (EC) No 552/2004 of the European Parliament and the Council of 10 March 2004 on the interoperability of the European Air Traffic Management network (the interoperability Regulation)

The indicated products comply with the regulations of the directives. This is proved by the compliance with the following standards:

Reference number	Specification
EN61000-6-2:2002	Electromagnetic compatibility Immunity for industrial environment
EN61000-6-3:2002	Electromagnetic compatibility Emission standard for residential, commercial and light industrial environments
EN61010-1:2001	Safety requirements for electrical equipment for measurement, control and laboratory use. Part 1: General requirements
EN60825-1:2001	Safety of laser products classification 1M

Place: **Göttingen**
Legally binding signature:

.....
Wolfgang Behrens

Date: 19.03.2007
issuer:

.....
Joachim Beinhorn

This declaration certifies the compliance with the mentioned directives, however does not include any warranty of characteristics. Please pay attention to the security advises of the provided instructions for use.